



## **Technical Specification**

### **MEF 4**

# **Metro Ethernet Network Architecture Framework - Part 1: Generic Framework**

**May 2004**

## Disclaimer

The information in this publication is freely available for reproduction and use by any recipient and is believed to be accurate as of its publication date. Such information is subject to change without notice and the Metro Ethernet Forum (MEF) is not responsible for any errors. The MEF does not assume responsibility to update or correct any information in this publication. No representation or warranty, expressed or implied, is made by the MEF concerning the completeness, accuracy, or applicability of any information contained herein and no liability of any kind shall be assumed by the MEF as a result of reliance upon such information.

The information contained herein is intended to be used without modification by the recipient or user of this document. The MEF is not responsible or liable for any modifications to this document made by any other party.

The receipt or any use of this document or its contents does not in any way create, by implication or otherwise:

- (a) any express or implied license or right to or under any patent, copyright, trademark or trade secret rights held or claimed by any MEF member company which are or may be associated with the ideas, techniques, concepts or expressions contained herein; nor
- (b) any warranty or representation that any MEF member companies will announce any product(s) and/or service(s) related thereto, or if such announcements are made, that such announced product(s) and/or service(s) embody any or all of the ideas, technologies, or concepts contained herein; nor
- (c) any form of relationship between any MEF member companies and the recipient or user of this document.

Implementation or use of specific Metro Ethernet standards or recommendations and MEF specifications will be voluntary, and no company shall be obliged to implement them by virtue of participation in the Metro Ethernet Forum. The MEF is a non-profit international organization accelerating industry cooperation on Metro Ethernet technology. The MEF does not, expressly or otherwise, endorse or promote any specific products or services.

© The Metro Ethernet Forum 2004. All Rights Reserved.

<b>MEF 4</b>	© The Metro Ethernet Forum 2004. Any reproduction of this document, or any portion thereof, shall contain the following statement: "Reproduced with permission of the Metro Ethernet Forum." No user of this document is authorized to modify any of the information contained herein.	
--------------	--	--

## Table of Contents

<b>1.</b>	<b>Abstract.....</b>	<b>3</b>
<b>2.</b>	<b>Terminology.....</b>	<b>3</b>
<b>3.</b>	<b>Scope.....</b>	<b>4</b>
<b>4.</b>	<b>Compliance Levels .....</b>	<b>4</b>
<b>5.</b>	<b>MEN Reference Model .....</b>	<b>5</b>
<b>6.</b>	<b>MEN Layer Network Model .....</b>	<b>6</b>
6.1	Ethernet Services Layer (ETH Layer).....	6
6.2	Transport Services Layer (TRAN Layer).....	7
6.3	Application Services Layer (APP Layer).....	7
<b>7.</b>	<b>MEN Reference Points .....</b>	<b>7</b>
7.1	User-Network Interface (UNI) .....	8
7.1.1	UNI Client (UNI-C).....	9
7.1.2	UNI Network (UNI-N).....	9
7.2	External Network-to-Network Interface (E-NNI).....	9
7.3	Internal Network-to-Network Interface (I-NNI).....	10
7.4	Network Interworking Network-to-Network Interface (NI-NNI).....	10
7.5	Service Interworking Network-to-Network Interface (SI-NNI).....	10
7.6	Other MEN Access Arrangements .....	11
7.6.1	Service Node Interface (SNI).....	11
<b>8.</b>	<b>MEN Architectural Components.....</b>	<b>11</b>
8.1	Topological Components.....	12
8.2	Transport Components .....	13
8.3	Processing Components (The MEN Functional Elements).....	13
8.3.1	Generic MEN Functional Elements .....	14
<b>9.</b>	<b>MEN Layers Relationship to the Architecture Model Components .....</b>	<b>15</b>
9.1	Operational Planes and the MEN Layer Networks .....	15
9.2	MEN Network Reference Model and the Topological Components .....	15
9.3	MEN Reference Link Model.....	17
<b>10.</b>	<b>References.....</b>	<b>19</b>

**Appendix I: Generic Transport Entities and Reference Points of a Layer Network ..... 20**

I.1 The Client/Server Layer Network Model ..... 20

I.2 Adaptation & Termination Functions ..... 21

I.3 Relationships between Connection-Oriented vs. Connectionless Components ..... 23

**Appendix II: MEN Physical Components ..... 25**

II.1 Customer Edge (CE) Equipment ..... 25

II.2 Provider Edge (PE) Equipment ..... 25

II.3 Provider (P) Core Equipment ..... 25

II.4 Network Termination (NT) Equipment ..... 26

II.5 Transport Edge (TE) Equipment ..... 26

## List of Figures

Figure 1: Basic Network Reference Model ..... 5

Figure 2: MEN Layer Network Model ..... 6

Figure 3: MEN External Interfaces and associated reference points ..... 8

Figure 4: The UNI and the MEN Reference Model ..... 9

Figure 5: Reference points for access arrangements into a MEN via an SNI ..... 11

Figure 6: Sample relationship between MEN Reference Model and the Architectural Components ..... 16

Figure 7: Sample decomposition of a MEN into layer networks and protocol stacks ..... 17

Figure 8: MEN Reference Link Model (Example) ..... 18

## List of Tables

Table I-1: Components of connection oriented and connectionless architectures ..... 24

## 1. Abstract

This document provides the Metro Ethernet Forum (MEF) generic architectural framework for Metro Ethernet Networks (MEN). The generic architecture framework describes the high-level constructs used to model the various architectural components of a MEN's Ethernet services, transport services and application services layer networks. The MEF architecture model is based on the principle of layer network decomposition, where each layer network is constructed from a particular set of networking technologies (e.g., Ethernet, SONET/SDH, MPLS, etc.). The model reuses the native Ethernet frame structure [2][3] and the architectural constructs created to describe connection and connection-less oriented transport networks in ITU-T Recommendations G.805 [4] and G.809 [6].

## 2. Terminology

Term	Definition
APP	Application Services Layer
ATM	Asynchronous Transfer Mode
CE	Customer Edge
CI	Characteristic Information
ESD	Ethernet Services Definition
ESM	Ethernet Services Model
ETH	Ethernet Services Layer
EVC	Ethernet Virtual Connection
FE	Functional Element
GbE	Gigabit Ethernet
IEEE	Institute of Electrical and Electronics Engineers
IWF	Interworking Function
ITU	International Telecommunication Union
L1	Layer One
L2	Layer Two
L2+	Layer(s) above L2
LAN	Local Area Network
MAC	Media Access Control
MEF	Metro Ethernet Forum
MEN	Metro Ethernet Network
MPLS	Multi Protocol Label Switching
NE	Network Element
NI-	Network Interworking (e.g., NI-NNI)
NNI	Network-to-Network Interface

Term	Definition
NT	Network Termination
OTN	Optical Transport Network
PDH	Plesiochronous Digital Hierarchy
PE	Provider Edge
RPR	Resilient Packet Ring
SDH	Synchronous Digital Hierarchy
SI-	Service Interworking (e.g., SI-NNI)
SNI	Service Node Interface
SONET	Synchronous Optical Network
TE	Transport Equipment
TRAN	Transport Services Layer
UNI	User to Network Interface
VLAN	Virtual LAN
WAN	Wide Area Network

### 3. Scope

The architecture framework provides the generic model used by the MEF to describe internal and external architectural components of a MEN. The document is intended to describe the layer network decomposition model for a MEN in terms of a) Ethernet services, transport services and application services layer networks components, and b) the generic architectural components associated with layer networks. The framework is also intended to describe the interactions among MEN architectural components across well-defined interfaces and their associated reference points. The architecture framework is not intended to require, or exclude, any specific networking technology from being used on any given implementation of a MEN. Yet, the generic architecture framework provides the common guidelines for the specification and decomposition of the MEN Ethernet transport and services capabilities. Detailed Technical Specifications and Implementation Agreements for specific architectural elements are outside the scope of this document.

### 4. Compliance Levels

The key words "**MUST**", "**MUST NOT**", "**REQUIRED**", "**SHALL**", "**SHALL NOT**", "**SHOULD**", "**SHOULD NOT**", "**RECOMMENDED**", "**MAY**", and "**OPTIONAL**" in this document are to be interpreted as described in RFC 2119. All key words must be use upper case, bold text.

## 5. MEN Reference Model

The basic network reference model of a MEN is depicted in Figure 1. Two major functional components are involved:

- i) the subscriber/customer edge equipment, and
- ii) the public MEN transport infrastructure

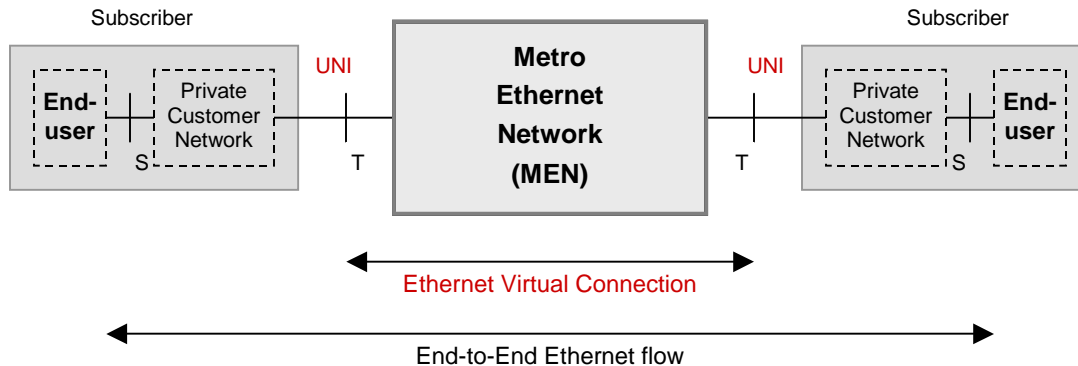

**Figure 1: Basic Network Reference Model**

Reference point T, also referred to as the UNI reference point, demarcates the boundaries between the public MEN and a private customer network. Reference point S is the conceptual point that demarcates the boundaries between the private customer network equipment, when present, and the end-user terminal equipment generating an Ethernet frame flow (see [8]). If no other private network infrastructure exists between the subscriber terminal equipment and the public MEN equipment, the S and T reference points coincide. Unless otherwise stated, the term subscriber/customer equipment will be used in this framework document to refer to all private customer equipment outside the MEN.

An *Ethernet flow* represents a particular (potentially non contiguous, e.g., consecutive Ethernet frames may belong to different flows) unidirectional stream of Ethernet frames that share a common treatment for the purpose of transfer steering across the MEN. In particular, an end-to-end Ethernet flow refers to the flow of Ethernet frames between the communicating terminal equipment (TE) that creates and terminates the Ethernet frames.

The *Ethernet Virtual Connection* (EVC) is the architecture construct that supports the association of UNI reference points for the purpose of delivering an Ethernet flow between subscriber sites across the MEN. There may be one or more subscriber flows mapped to a particular EVC (e.g., there may be more subscriber flows identified by the flow classification rules at the ingress point to a network than EVCs). The mapping of Ethernet flows to EVCs is service specific and specified in the MEF Ethernet Service Model specification (see [9]).

## 6. MEN Layer Network Model

The MEN layer network model specified in this architecture framework defines the MEN in terms of three layer network (see Section 8.1) components: the Ethernet Services Layer supporting basic Layer 2 (L2) Ethernet data communication services; a set of one or more supporting Transport Services Layer(s) and, an optional Application Services Layer supporting applications carried on the basic L2 Ethernet services. The layer network model is based on a client/server relationship (See Appendix I, Section I.2). In addition, each of these layer networks may be further decomposed into their data, control and management plane components. This layer network view of a MEN is illustrated in Figure 2.

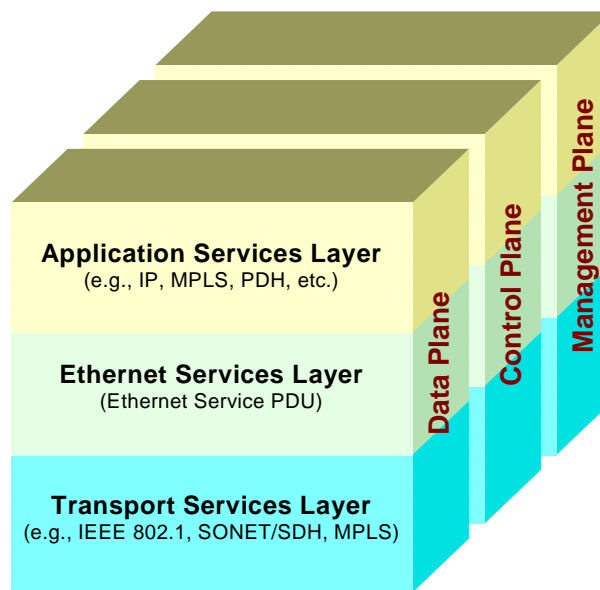

**Figure 2: MEN Layer Network Model**

### 6.1 Ethernet Services Layer (ETH Layer)

The Ethernet Services Layer, also referred to as the ETH Layer, is responsible for the instantiation of Ethernet MAC oriented connectivity services and the delivery of Ethernet service frames presented across well-defined internal and external interfaces and associated reference points. The ETH layer is also responsible for all service-aware aspects associated with Ethernet MAC flows including operations, administration, maintenance and provisioning capabilities required to support such Ethernet connectivity services. The service frame presented by the ETH layer external interfaces is an Ethernet unicast, multicast or broadcast frame conforming to the IEEE 802.3-2002 frame format (see [2]). The Ethernet Services layer is a single layer network.

The detailed architecture framework for the Ethernet Services Layer is provided in a separate Ethernet Layer Framework Architecture document.

## 6.2 Transport Services Layer (TRAN Layer)

The Transport Layer, also referred to as the TRAN Layer, supports connectivity among ETH layer functional elements in a service independent manner. Various layer network technologies and interconnect approaches may be used to support the transport requirements for the Ethernet services layer. Sample transport layer networks include IEEE 802.3 PHY, IEEE 802.1 bridged networks, SONET/SDH High Order/Low Order path networks, ATM VC, OTN ODUk, PDH DS1/E1, MPLS LSP, etc. Those transport layers are supported by their respective server layers; e.g., SDH STM-N Multiplex Section, ATM VP, OTN OTUk, PDH DS3/E3, MPLS LSP, IP, fiber, etc. This model may be applied recursively downwards into the transport layer network stack until the physical transmission medium (fiber, copper, coax, wireless) is reached.

## 6.3 Application Services Layer (APP Layer)

The Application Services Layer, also referred to as the APP Layer, supports applications carried on the basic Ethernet services across the MEN. Various application services may be supported over the basic Ethernet services supported by the Ethernet services layer. Sample services include the use of ETH layer as a TRAN layer for other layer networks such as IP, MPLS, PDH DS1/E1, etc. The APP Layer may also include add-on functions to complement ETH layer services. Each application services layer may support one or more application services layers. This model may be applied recursively upwards into the application layer network stack.

## 7. MEN Reference Points

A MEN reference point identifies a set of layer network reference points used for demarcating administrative boundaries where a link traverses open interfaces specified by the MEF. Figure 3 shows the relationship among external architectural components to a MEN, their associated interfaces and their reference points. External components to a MEN include a) the Subscribers to the MEN services, b) other MEN networks, and c) other (non-Ethernet) Transport and Service Networks. Subscribers connect to a MEN at a User-Network Interface reference point. Internal network elements (NE) are interconnected via Internal Network-to-Network Interfaces, or I-NNIs (not shown). Two autonomous MEN may interconnect at an External NNI (E-NNI) reference point. A MEN may interconnect with other Transport and Service networks at a Network Interworking NNI (NI-NNI) or a Service Interworking NNI (SI-NNI) reference point. An Ethernet Wide Area Network (E-WAN) refers to any MEF defined ETH services (see [9]) aware network that provides connectivity between two or more MENs via E-NNIs.

A MEN may use non-Ethernet based transport and service elements as internal architectural components. In some cases these architectural components may be integrated in a single network element (NE). In the latter case, an integrated and hybrid MEN may be deployed such that the

NI-NNI and/or SI-NNI are logical reference points within particular network equipment in the MEN.

Note that any of the transport/services networks identified in Figure 3 may indeed belong to the same Service Operator (e.g., they may represent different business units with the same company).

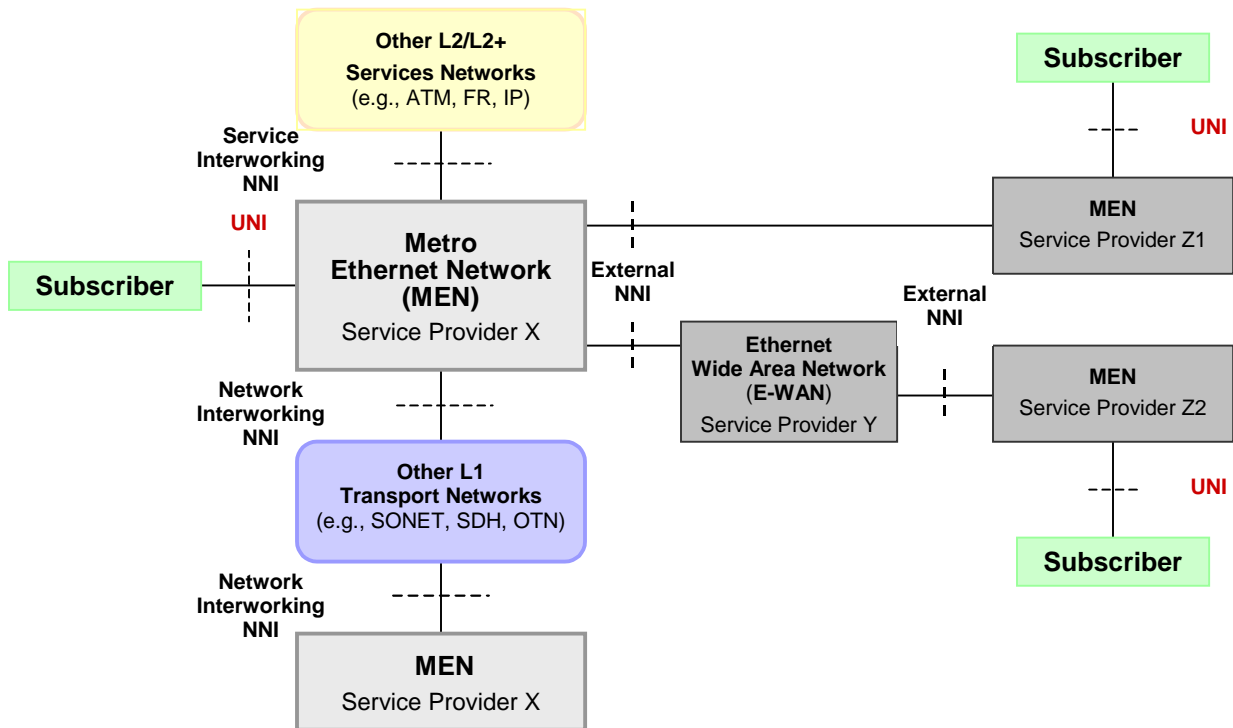

**Figure 3: MEN External Interfaces and associated reference points**

### 7.1 User-Network Interface (UNI)

The UNI is the interface used to interconnect a MEN subscriber to its MEN service provider(s). The UNI also provides a reference point for demarcation between the MEN operator’s equipment that enables access to the MEN services and the subscriber access equipment. Therefore, the demarcation point indicates the location where the responsibility of the service provider ends, and the responsibility of subscriber begins. The specific location of the UNI reference point (T) is specified in the MEF UNI document.

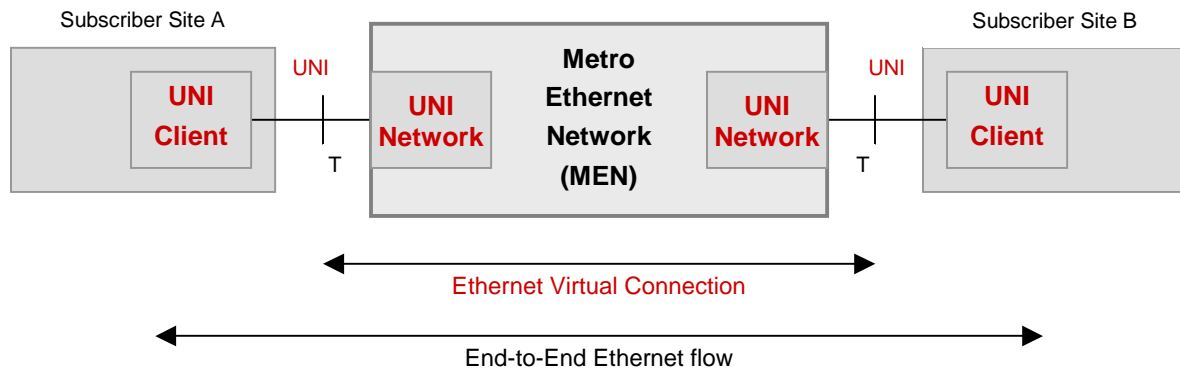

**Figure 4: The UNI and the MEN Reference Model**

Functionally the UNI is an asymmetric, compound functional element that consists of a client side, referred to as the UNI-C, and a network side, referred to as the UNI-N, as illustrated in Figure 4. Thus, the term UNI is used to refer to these two functional elements, and generically, to the data, management and control plane functions associated with them.

### 7.1.1 UNI Client (UNI-C)

The UNI-C is a compound architectural component of a MEN that represents all of the functions required to connect a subscriber to a MEN. Individual functions in a UNI-C are entirely in the subscriber domain, and may or may not be managed by the service provider/network operator. From the perspective of the MEN, the UNI-C supports the set of functions required to exchange data, control and management plane information with the MEN subscriber. As such, the UNI-C includes functions associated with the Ethernet services infrastructure, the transport network infrastructure, and (if present) application specific components.

### 7.1.2 UNI Network (UNI-N)

The UNI-N is a compound architectural component of a MEN that represents all of the functions required to connect a MEN to a MEN subscriber. The individual functions in a UNI-N are entirely in the service provider/network operator domain. From the perspective of the subscriber, the UNI-N supports the set of functions required to exchange data, control and management plane information with the MEN. As such, the UNI-N includes functions associated with the Ethernet services infrastructure, the transport network infrastructure, and (if present) application specific components.

## 7.2 External Network-to-Network Interface (E-NNI)

The E-NNI is an open interface used to interconnect two MEN service providers. The E-NNI provides a reference point for network equipment and Ethernet service demarcation between the

two directly attached MENs. The E-NNI also provides a reference point for NEs and Ethernet service demarcation between a MEN and an Ethernet service aware Wide Area Network (E-WAN). Transport interfaces and Network Interworking capabilities other than those associated with native Ethernet physical interfaces (e.g., see Section 7.4) MAY be supported across this interface. In addition, the term E-NNI is used to refer generically to the protocol exchange that exists at the E-NNI reference point between the architectural elements in each of the MENs that support the E-NNI delineation functions. The specific location of the E-NNI reference point is specified in the MEF E-NNI framework document.

### **7.3 Internal Network-to-Network Interface (I-NNI)**

The I-NNI is an open interface used to interconnect NEs from a given MEN service providers. The I-NNI provides a reference point for Ethernet service demarcation between the two directly attached NEs. Transport interfaces and Network Interworking capabilities other than those associated with native Ethernet physical interfaces (e.g., see Section 7.4) MAY be supported across this interface. In addition, the term I-NNI is used to refer generically to the protocol exchange that exists at the I-NNI reference point between the architectural elements in each of the MENs that support the I-NNI delineation functions.

### **7.4 Network Interworking Network-to-Network Interface (NI-NNI)**

The NI-NNI is an open interface that supports the extension of transport facilities used to support Ethernet services, and associated EVCs, over an external transport network(s) not directly involved in the end-to-end Ethernet service. The NI-NNI is intended to preserve the characteristic information (see Section 8.1) of a subscriber's flow. The NI-NNI also provides a reference point for demarcation between the two MEN service provider interfaces attached via public transport networks. Examples of other public transport networks include OTN, SDH/SONET, ATM, Frame Relay, RPR, etc. The term NI-NNI is also used in this document to refer to the protocol exchange that exists at the NI-NNI reference point and the architectural element in each of the MENs responsible for the support of the NI-NNI delineation functions (NI-NNI IWF).

### **7.5 Service Interworking Network-to-Network Interface (SI-NNI)**

The SI-NNI is an interface that supports the interworking of an MEF service with services provided via other service enabling technologies (e.g., Frame Relay, ATM, IP, etc.). The SI-NNI provides a reference point for demarcation between a MEN and another public service network. Examples of other public services networks include ATM, Frame Relay and IP. The term SI-NNI is also used in this document to refer to the protocol exchange that exists at the SI-NNI reference point and the architectural element in each of the MENs responsible for the support of the SI-NNI delineation functions (SI-NNI IWF).

## 7.6 Other MEN Access Arrangements

The basic MEN reference model illustrated in Figure 4 presumes a one-to-one relationship between the MEN subscriber port and the MEN service provider port. Indirect means of access into the service provider equipment supporting the UNI functions, e.g., via a so-called feeder or Access Networks, may be required in deployment scenarios where Ethernet services are introduced over pre-existing access technologies (e.g., PDH, SONET/SDH or Hybrid Fiber/Coaxial networks), or over an alternative Ethernet transport facilities.

### 7.6.1 Service Node Interface (SNI)

The Service Node Interface (SNI) is an interface that supports the extension of the MEF UNI capabilities across an intermediate access network not directly involved in the end-to-end Ethernet service. As illustrated in Figure 5 the SNI provides a reference point for demarcation between the network location where Ethernet Service attributes are enforced [9] and a packet-aware Access Network that aggregates subscriber flows at a packet level (layer 2) into a common transport channel. In this scenario, the UNI and SNI reference points are equivalent to T ( $T_B$ ) and V ( $V_B$ ) in the ISDN (B-ISDN) terminology [7]. The Access Network strictly provides a packet-based transport function for the access portion of the connection between the subscriber and the MEN. For this reason the SNI reference point is also informally referred to as the Virtual UNI reference point. As such, the SNI is intended to preserve in a transparent manner the characteristic information. (see Section 8.1) of a subscriber's flow. The specific location of the SNI reference point is specified in the MEF TMF specification.

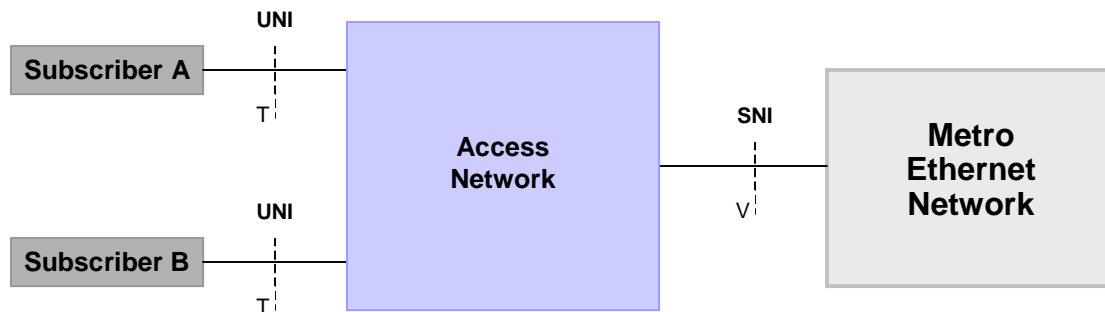

Figure 5: Reference points for access arrangements into a MEN via an SNI

## 8. MEN Architectural Components

A functional modeling approach is used in this framework to represent the various architecture components of all the layer network of a MEN. The functional model is based on the architectural constructs created to describe connection and connection-less oriented transport networks in ITU-T Recommendations G.805 [4] and G.809 [6]. This chapter describes the main

architectural concepts defined by these two Recommendations as related to MEF architecture framework. Three types of architectural components are identified: a) Topological Components, b) Transport Components, and c) Processing Components. Topological and transport components are used to represent abstract connectivity constructs. Processing components are used to represent abstract system components that affect information transfer. These concepts are further discussed in this section. Formal definition of topological components, transport entities and reference points can be found in the ITU-T Recommendations G.805 and G.809.

## 8.1 Topological Components

A *topological component* provides the highest level of abstraction for the description of an architectural component of a transport network. It defines inclusion/exclusion relationships between sets of like functions and associated reference points. There are four topological components of interest:

- **Layer Network:** A complete set of logical or physical ports (see also access group) of the same type that may be associated for the purpose of transferring information. The transferred information is in terms of a well-defined traffic unit of the particular layer network and it is termed its Characteristic Information (CI).
- **Subnetwork:** A partition of a layer network used to affect the steering of specific user data within a portion of a layer network. In the ITU-T terminology the term subnetwork is reserved for connection oriented networks (see [4]). The term *Flow Domain* is used in the context of a connectionless layer network (see [6]), such as Ethernet.
- **Link:** A (fixed) connectivity relationship between a "subnetwork" or "access group" and another "subnetwork" or "access group". The term *Flow Point Pool Link* are used in the context of a connectionless layer network (see [6]), such as Ethernet.
- **Access Group:** A group of co-located logical or physical ports, with associated processing functions that are connected to the same "subnetwork" or "link". Basically, an access group represents the logical access ports into a given sub-network or flow domain.

CI is defined in ITU-T Recommendation G.805. It is used to specify units of information, including a specific unit format, which is transferred on "connections" within the given layer network. The CI format is always defined in a technology specific manner for each network layer in their associated architecture framework document.

The Ethernet MAC layer, the IP network layer, the SONET/SDH High Order/Low Order layers or even a fiber infrastructure are example of layer networks. . See Appendix I Section I.1 for further illustration of the relationships between topological components of a layer network.

## 8.2 Transport Components

A *transport component*, or *transport entity*, provides the means to affect the transfer of information between reference points. Two types of transport entities, and their associated reference points, are defined:

- **Connection:** A transport entity that represents an aggregation of one or more connection oriented traffic units with an element of common routing. Referred to as *Flow* in the context of a connectionless layer network.
- **Connection Point:** A reference point that represents a location of transfer of connection-oriented traffic units between topological components. Referred to as a *Flow Point/Flow Point Pool* in the context of a connectionless layer network.
- **Trail:** A transport entity that represents the transfer of monitored and adapted characteristic information of client layer network between two access points. Typically used to represent the association between source and destination(s) on a per traffic unit basis. Referred to as a *Connectionless Trail* in the context of a connectionless layer network.
- **Trail Termination Point:** A reference point that represents a location of insertion/extraction of monitored and adapted information characteristic to a given layer network (as opposed to the information presented by the client of the layer network). Referred to as a *Flow Termination Point* in the context of a connectionless layer network.
- **Access Point:** A reference point where the output (input) of a "trail termination" is bound to the input (output) of an "adaptation" or the output of an "adaptation" function.

Appendix I provides additional description of these transport entities, and reference points, and their relationship to topological components.

## 8.3 Processing Components (The MEN Functional Elements)

A *processing component* provides the actual means to affect the transfer of information at a given reference point. The concept of a Functional Element (FE) is used in this architecture framework to represent the specific set of processes, or functions, within the MEN services or transport network that act on a particular collection of input data to produce a specific collection of output data. Functional elements may also be used to represent compound functions, i.e., a collection of other pre-defined functional elements

It is the intent of the MEF architecture framework to adopt existing functional elements, and associated functional models, from accredited standards organizations and industry fora. In particular, functional elements for Ethernet LANs are derived from IEEE 802.3-2002 and IEEE

802.1Q-1998 specifications. Functional models for connection-oriented functional elements are derived from the ITU-T Recommendations G.805. Functional models for connectionless functional elements are derived from the ITU-T Recommendations G.809. Detailed functional models for functional elements in the MEN architecture framework are outside the scope of this framework document.

### 8.3.1 Generic MEN Functional Elements

Two generic functional elements are defined in ITU-T Recommendations G.805 and G.809 to distinguish the processes required to a) adapt a client signal for transport across a server layer network, and b) generate a traceable flow/connection across the layer network. Both source and sink versions of the processes are defined:

- **Adaptation Function:** A transport processing function that converts the server layer network trail information into the characteristic information of the client layer network (and vice versa).
- **Termination Function:** A transport processing function which accepts adapted characteristic information from a client layer network at its input, adds information to allow the associated trail to be monitored (if supported) and presents the characteristic information of the layer network at its output(s) (and vice versa).

Note that the Adaptation Function is an inter-layer function that contains processing aspects of both the client and the server layer networks.

In addition, ITU Recommendation G.806 defines a generic functional element to steer flows within a network:

- **Connection Function:** A transport processing function that transfers information (potentially transparently) from a given input to one or more outputs. Note that a Connection Function is the smallest subnetwork / flow domain (also referred to as Flow Domain Function).

Appendix I, Section I.3, provides further description for these functions and illustrates their relationship to other topological components.

When dealing with a physical instantiation of a MEN it is useful to refer to some network elements implementing specific functions defined in an MEF specification. Appendix II provides informal definitions of common terms used to refer to networks elements implementing some of the functions defined in this document.

## 9. MEN Layers Relationship to the Architecture Model Components

This section discusses the relationships between the ETH, TRAN and APP layers, the operational planes and the generic topological components.

### 9.1 Operational Planes and the MEN Layer Networks

The three operational planes are distinguished:

- Data Plane
- Control Plane
- Management Plane

The Data Plane, also referred to as the user/transport/forwarding plane, provides the functional elements required to steer the subscriber flow, and supports the transport of subscriber traffic units among MEN NEs.

The Control Plane provides the functional elements that support distributed flow management functions among NEs participating in the MEN data plane. The control plane also provides the signaling mechanisms necessary to support distributed set up, supervision and connection release operations, among other flow control functions.

The Management Plane provides the functional elements that support Fault, Configuration (including flow and/or connection configuration), Account, Performance and Security (FCAPS) functions, as well as any related Operations, Administration and Maintenance (OAM) tools.

Subscribers and external networks connected to a MEN are likely to include similar layers and planes. The information exchange between the subscriber and MEN Management and Control Planes across at defined reference points is restricted (and may be absent) according to the implementation agreements for the UNI, NNI and other external IWF.

### 9.2 MEN Network Reference Model and the Topological Components

A MEN itself consists of physical components (e.g., network elements, ports, etc.) and logical components (e.g., meters, policers, shapers, virtual switches, links, etc.). A MEN architecture is further described by defining the associations between points in the network and the interconnected topological and/or functional components.

The partition of a MEN into layer networks places a bound on the scope of the various MEN topological and functional components. Access groups connect customers from the client layer network to the services supported by the server layer network in a client/server relationship. Formally, a reference point describes any binding between input and output of processing functions or transport entities (see ITU-T Recommendations G.805 and G.809).

The relationship between the MEN reference model, its layer networks and topological components is illustrated in Figure 6. Note that within a particular service provider network multiple Ethernet layer network domains (e.g., ETH Subnetwork A and ETH Subnetwork B) and different kinds of transport technologies (e.g., TRAN Subnetwork A, TRAN Subnetwork B and TRAN Subnetwork C) may be used to instantiate a particular MEN.

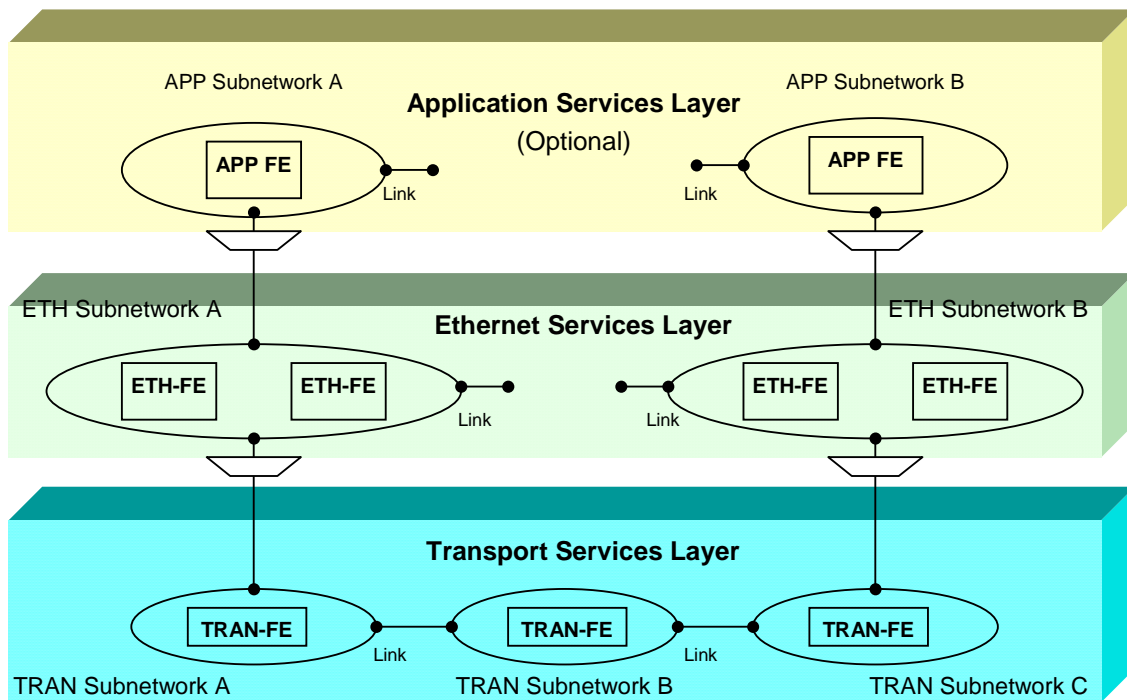
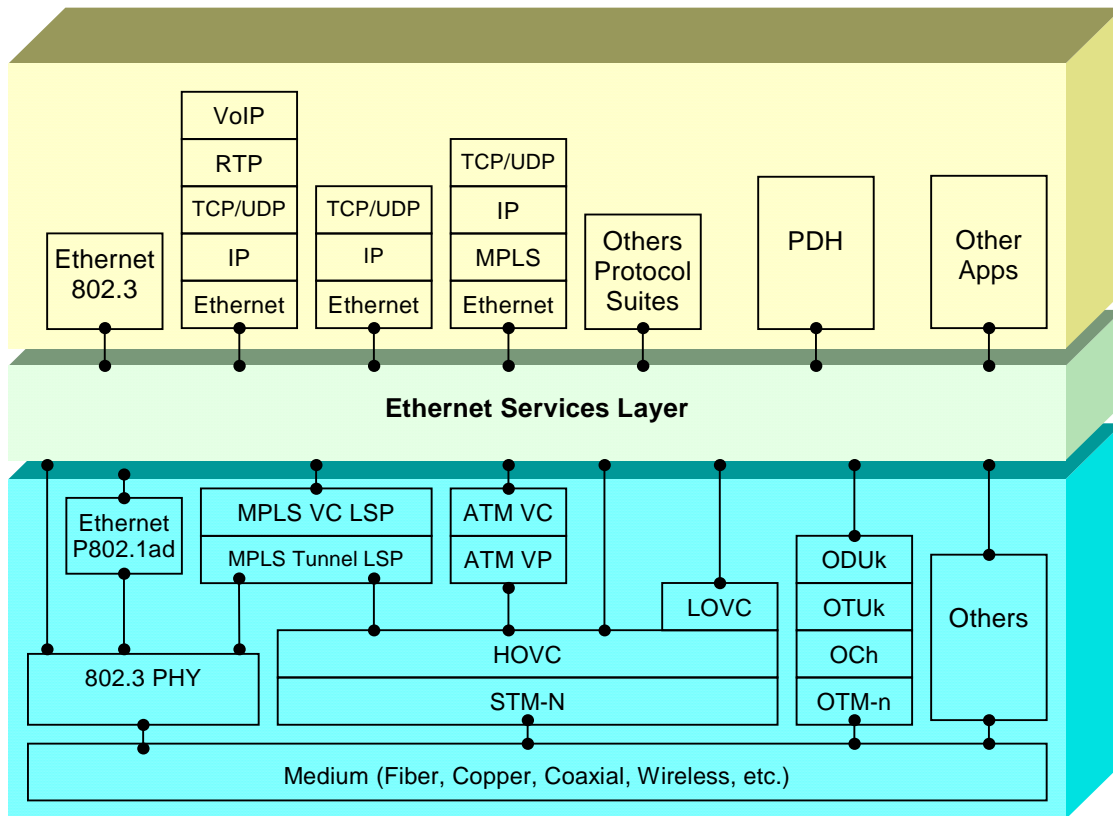

**Figure 6: Sample relationship between MEN Reference Model and the Architectural Components**

Note also that a given layer network (e.g., IP, MPLS, SONET/SDH, PDH) may play a dual role with the Ethernet services layer:

- as a transport layer providing transport services to the Ethernet service layer, and
- as an application service layer using the service provided by the Ethernet service layer.

For instance, the Transport and Application Services Layers may be further partitioned into additional layer networks and associated protocols. This generic layer network modeling principle is illustrated in Figure 7. For a compound functional element XYZ that expands multiple layer networks, the term APP XYZ, ETH XYZ and TRAN XYZ are used to refer to the specific set of functional elements within the compound functional element that form part of the APP, ETH and TRAN layers, respectively (if present).



**Figure 7: Sample decomposition of a MEN into layer networks and protocol stacks**

### 9.3 MEN Reference Link Model

The term “link” is used in this architecture framework to refer to a "topological component" that describes a fixed connectivity relationship, and available transport capacity, between a pair of subnetworks (flow domains), or a subnetwork (flow domain) and an access group or a pair of access groups. From the point of view of the MEN architecture framework, links are further classified according to the MEN layer network they support and their relationship to internal/external reference point.

Links may be used in a variety of different arrangements to produce more complex link models. For instance, a link at layer network N may be instantiated by one or more links at layer network n-1 to create a *nested link*. Multiple layer network N links may be aggregated into a single layer N link to create a *compound link*. In this arrangement each aggregated link is also referred to as a component link.

With respect to the MEN reference points (Figure 3), this framework document classifies links in two classes:

- **Access Link:** A link that provides connectivity across an UNI reference point
- **Trunk Link:** A link that provides connectivity across an NNI reference point

With respect to the MEN layer network(s), this framework document classifies links into three classes:

- **APP Link:** A link in (one of) the APP layer(s)
- **ETH Link:** A link in the ETH layer
- **TRAN Link:** A link in (one of) the TRAN layer(s)

Multiple links may exist between any given subnetwork (flow domains) and access group or pair of subnetworks (flow domains) or access groups. While links are established and maintained at the time scale of the server layer network (e.g., EMS/NMS provisioned links vs. control plane provisioned links), they are not limited to being provided by a server layer network and can also be provided by client layer network connections. Figure 8 illustrates the high-level relationship between link types and the MEN UNI and E-NNI reference points. Separate specifications will provide detailed relationships between processing functions and reference points for any MEF specified interface.

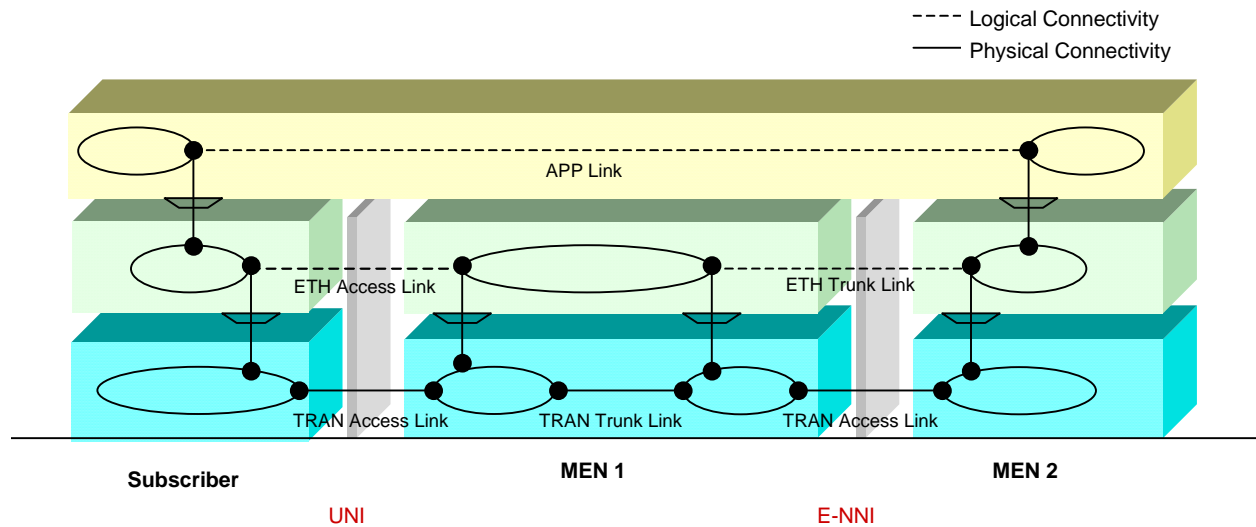

**Figure 8: MEN Reference Link Model (Example)**

## 10. References

- [1] IETF RFC 2119, "Key words for use in RFCs to Indicate Requirement Levels", S. Bradner, <http://www.ietf.org/rfc/rfc2119.txt>
- [2] Information technology – Telecommunications and information exchange between systems – Local and metropolitan area networks – Specific requirements – Part 3: Carrier sense multiple access with collision detection (CSMA/CD) access method and physical layer specifications, March 2002.
- [3] "Virtual Bridged Local Area Networks",  
<http://standards.ieee.org/reading/ieee/std/lanman/802.1Q-1998.pdf>
- [4] TU-T Recommendation G.805 "*Generic functional architecture of transport networks.*" March 2002.
- [5] ITU-T Recommendation G.806 "*Characteristics of transport equipment – Description methodology and generic functionality.*" March 2003.
- [6] ITU-T Recommendation G.809 "*Functional architecture of connectionless layer networks.*" March 2003.
- [7] ITU-T Recommendation I.902 "*Framework Recommendation on functional access networks (AN) - Architecture and functions, access types, management and service node aspects*"
- [8] ITU-T Recommendation I.324 "*ISDN Network Architecture.*" 1991.
- [9] MEF 1, "MEF Ethernet Services Model, Phase 1." November 2003

## Appendix I: Generic Transport Entities and Reference Points of a Layer Network

(Informational)

The concept of a *Topological Component* is being used in this framework document to provide abstract description of generic network components in terms of the topological relationships between sets of like reference points. Layer networks, subnetworks/flow domains, access groups and links are generic topological components a network architecture as defined by ITU-T. In addition, the concepts of transport entities and reference points, in relationship to other topological components, are also defined. Some of the more relevant transport entities, and associated reference points, to the architectural framework in the MEF are:

- **Flow:** A transport entity that represents an aggregation of one or more connectionless traffic units with an element of common routing
- **Flow Point:** A reference point that represents a point of transfer for connectionless traffic units between topological components
- **Connection:** A transport entity that represents an aggregation of one or more connection oriented traffic units with an element of common routing
- **Connection Point:** A reference point that represents a point of transfer for connection-oriented traffic units between topological components
- **Trail:** A transport entity that represents the transfer of monitored and adapted characteristic information of client layer network between two access points. Typically used to represent the association between source and destination(s) on a per traffic unit basis. Also referred to as a *Connectionless Trail* within the context of connectionless networks.
- **Access Point:** A reference point that represents the binding between a client and a server layer network

Formal definitions of topological components, transport entities and reference points can be found in the ITU-T Recommendations G.805 and G.809.

### I.1 The Client/Server Layer Network Model

The layer network model is based on a client/server relationship. In general, as illustrated in Figure I.1, a layer “n”:

- uses the transport service provided by a trail in a lower layer “n” (Layer Network Y), and
- provides a transport service via a trail in its layer to a higher layer “n+1”.

The service is provided via a layer X to layer X+1 adaptation function, which adapts the *characteristic information* of the layer X+1 for transport over the layer X trail.

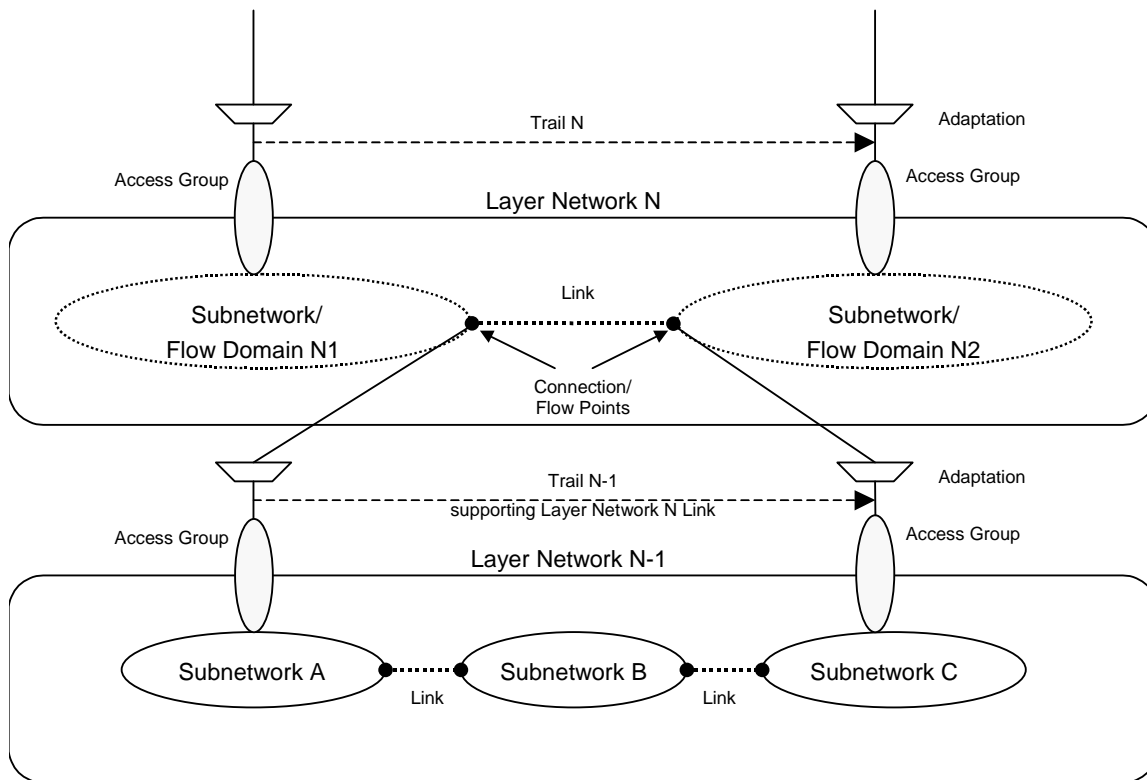

**Figure I.1: Relationship between topological components, access points and trails**

## I.2 Adaptation & Termination Functions

Two generic functional elements are defined in ITU-T Recommendations G.805 and G.809 to distinguish the processes required to a) adapt a client signal for transport across a server layer network, and b) generate a traceable flow/connection across the layer network. Both source and sink version of the processes are defined:

- **Adaptation source:** A transport processing function that adapts the client layer network characteristic information into a form suitable for transport over a trail (in a connection oriented server layer network) or connectionless trail (in a connectionless server layer network) in the server layer network.
- **Adaptation sink:** A transport processing function which converts the server layer network trail (in a connection oriented server layer network) or connectionless trail (in a connectionless server layer network) information into the characteristic information of the client layer network
- **Termination source:** A transport processing function which accepts adapted characteristic information from a client layer network at its input, adds information to allow the associated trail to be monitored (if supported) and presents the characteristic information of the layer network at its output(s)
- **Termination sink:** A transport processing function which accepts the characteristic information of the layer network at its input, removes the information related to connectionless trail monitoring and presents the remaining information at its output

A typical relationship between adaptation/termination functions, topological components, networks entities and reference points according to ITU-T Recommendation G.809 is illustrated in Figure I-2.

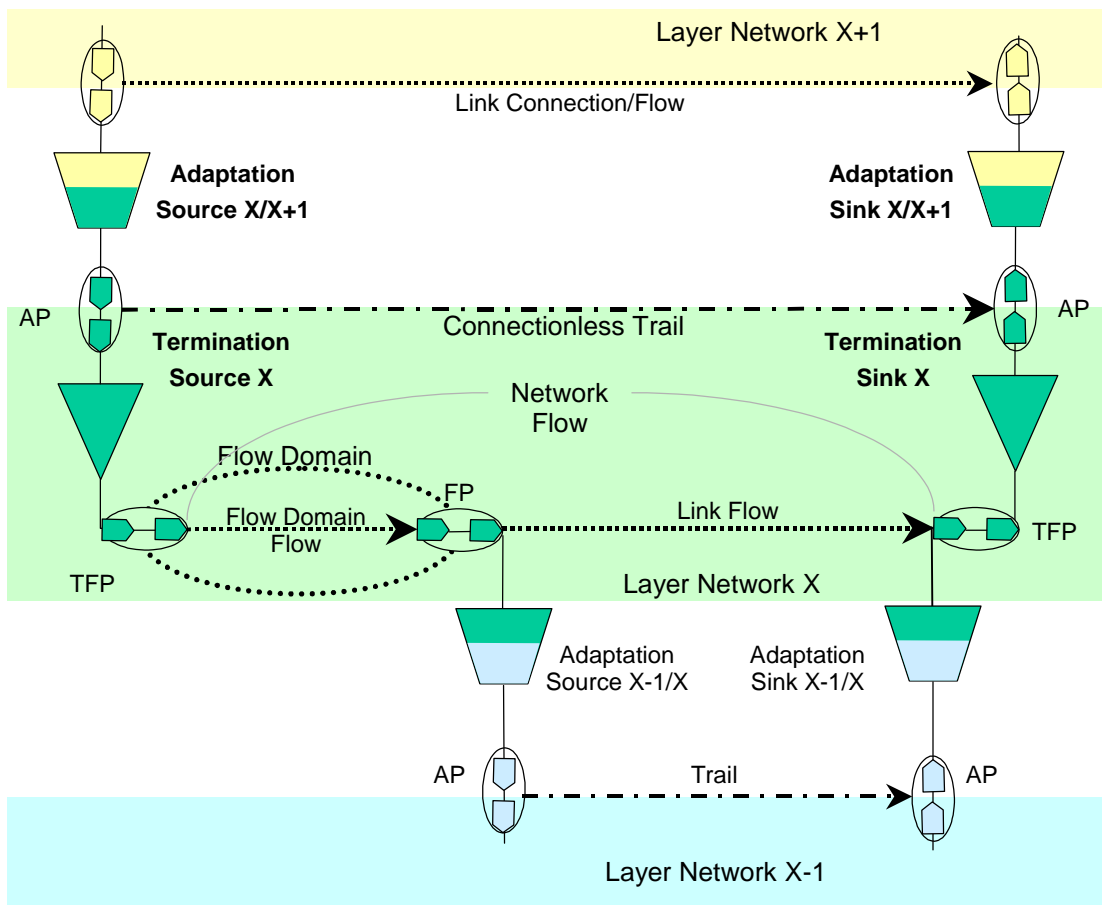

**Figure I-2: Typical relationship between adaptation/termination functions, topological components, networks entities and reference points**

### I. 3 Relationships between Connection-Oriented vs. Connectionless Components

ITU-T Recommendation G.809 describes in a generic manner the processes performed on “flows” by processing components in a connectionless layer. ITU-T Recommendation G.809 currently defines “flow” as the equivalent to various styles of “connections” defined in Recommendation G.805. Although the terms “flow” and “connection” are used to describe equivalent topologically components, distinct names are used to emphasize the connection-oriented vs. connectionless aspects of the underlying transport mechanism. Thus, the terms “network connection”, “subnetwork connection” and “link connection” translate into “network flow”, “flow domain flow” and “link flow” in Recommendation G.809.

Table I-1 contrasts components of a connection-oriented architecture based on G.805 with their counterparts of the connectionless architecture described in G.809.

**Table I-1: Components of connection oriented and connectionless architectures**

<b>Connection oriented component</b>	<b>Connectionless component</b>
(Unidirectional) Connection	<b>Flow</b>
(Unidirectional) Connection point	<b>Flow point</b>
(Unidirectional) Termination connection point	<b>Termination flow point</b>
Access point	Access point
Layer network	Layer network
Subnetwork	<b>Flow Domain</b>
Access group	Access group
Link	<b>Flow point pool link</b>
Network connection	<b>Network flow</b>
Subnetwork connection	<b>Flow domain flow</b>
Adaptation	Adaptation
Adaptation sink	Adaptation sink
Adaptation source	Adaptation source
Trail	<b>Connectionless trail</b>
Trail termination	<b>Flow termination</b>
Trail termination sink	<b>Flow termination sink</b>
Trail termination source	<b>Flow termination source</b>

## Appendix II: MEN Physical Components

(Informative)

A MEN physical component refers to a Network Element in a MEN that instantiates specific logical components of the MEN architecture. The physical equipment may include functional elements that span across multiple MEN layers and planes.

### II.1 Customer Edge (CE) Equipment

The CE equipment is a physical element of the MEN architecture that contains all of the functional elements in the customer network required to request services from a MEN. Individual functional elements in a CE may be either entirely in the subscriber domain, or may be entirely in the service provider domain (and managed by the service provider/network operator). From the perspective of the MEN, the CE must support at the minimum the set of functions associated with the UNI-C. The CE may be implemented by an (Ethernet) Switch, (IP/MPLS) Router or a Host System. As such, the CE includes functional elements at the ETH, TRAN layers, and (optionally) APP layers.

### II.2 Provider Edge (PE) Equipment

The PE equipment is a physical element of the MEN architecture that contains the functional elements in the MEN required to support either

- a subscriber access link
- an access link to another external network

in the ETH layer. There may be TRAN layer physical components between a PE and its associated CE(s). From the perspective of the Subscriber, the PE supports at a minimum the set of functions associated with UNI-N. The subscriber itself has no other perspective of the physical/logical implementation of the PE. A subscriber sees the functions provided via the UNI DCE.

### II.3 Provider (P) Core Equipment

The P core equipment is a physical element of the MEN architecture that represents any other provider equipment participating in ETH layer network that does not support any functional elements associated with a PE. There may be TRAN layer physical components between a P device and other P/PE devices in the service provider network. From the perspective of the Provider, the P devices are those that do not participate in UNI-N/E-NNI functions.

## II.4 Network Termination (NT) Equipment

The NT equipment is a physical device that supports the functional elements associated with the end point of the provider TRAN layer network and the beginning of the Subscriber TRAN layer network. The NT's responsibilities include physical medium performance monitoring, timing, line encoding/conversion, among others.

## II.5 Transport Edge (TE) Equipment

The TE equipment is a physical device that enables TDM/packet multiplexing of multiple customer flows into single physical link. The TE equipment does not need to be able to inspect Ethernet frames generated by a subscriber. A TE may also be a converter from one TRAN type to another.