



Technical Specification

MEF 3

Circuit Emulation Service Definitions, Framework and Requirements in Metro Ethernet Networks

April 13, 2004

Disclaimer

The information in this publication is freely available for reproduction and use by any recipient and is believed to be accurate as of its publication date. Such information is subject to change without notice and the Metro Ethernet Forum (MEF) is not responsible for any errors. The MEF does not assume responsibility to update or correct any information in this publication. No representation or warranty, expressed or implied, is made by the MEF concerning the completeness, accuracy, or applicability of any information contained herein and no liability of any kind shall be assumed by the MEF as a result of reliance upon such information.

The information contained herein is intended to be used without modification by the recipient or user of this document. The MEF is not responsible or liable for any modifications to this document made by any other party.

The receipt or any use of this document or its contents does not in any way create, by implication or otherwise:

- (a) any express or implied license or right to or under any patent, copyright, trademark or trade secret rights held or claimed by any MEF member company which are or may be associated with the ideas, techniques, concepts or expressions contained herein; nor
- (b) any warranty or representation that any MEF member companies will announce any product(s) and/or service(s) related thereto, or if such announcements are made, that such announced product(s) and/or service(s) embody any or all of the ideas, technologies, or concepts contained herein; nor
- (c) any form of relationship between any MEF member companies and the recipient or user of this document.

Implementation or use of specific Metro Ethernet standards or recommendations and MEF specifications will be voluntary, and no company shall be obliged to implement them by virtue of participation in the Metro Ethernet Forum. The MEF is a non-profit international organization accelerating industry cooperation on Metro Ethernet technology. The MEF does not, expressly or otherwise, endorse or promote any specific products or services.

© The Metro Ethernet Forum 2004. All Rights Reserved.

Table of Contents

1. ABSTRACT	8
2. TERMINOLOGY	8
3. SCOPE	10
4. COMPLIANCE LEVELS	10
5. MEF DOCUMENT ROADMAP	10
6. CIRCUIT EMULATION SERVICE DEFINITION	11
6.1 TDM LINE SERVICE (T-LINE)	11
6.1.1 <i>Operational Modes of a T-Line Service</i>	12
6.1.1.1 Unstructured Emulation mode	12
6.1.1.2 Structured Emulation mode	13
6.1.1.3 Multiplexing mode.....	13
6.1.2 <i>Bandwidth Provisioning for a T-Line Service</i>	14
6.1.2.1 Bandwidth allocation at 100 kbit/s granularity	14
6.1.2.2 TDM multiplexing	14
6.1.2.3 Ethernet multiplexing	15
6.2 TDM ACCESS LINE SERVICE (TALS).....	15
6.2.1 <i>Operational Modes of a TALS Service</i>	16
6.3 CUSTOMER OPERATED CES	17
6.4 MIXED-MODE CES OPERATION	18
7. CIRCUIT EMULATION SERVICE FRAMEWORK	19
7.1 GENERAL PRINCIPLES.....	19
7.1.1 <i>Use of External Standards</i>	19
7.2 SERVICE INTERFACE TYPES	19
7.2.1 <i>Examples of TDM Service Interfaces</i>	20
7.2.2 <i>TDM Service Processor (TSP)</i>	20
7.2.3 <i>Circuit Emulation Inter-working Function (CES IWF)</i>	21
7.2.3.1 PDH Circuit Emulation Service	22
7.2.3.2 SONET/SDH Circuit Emulation Service	22
7.2.4 <i>Emulated Circuit De/Multiplexing Function (ECDX)</i>	23
7.2.5 <i>Ethernet Flow Termination Function (EFT)</i>	23
7.2.6 <i>Direction terminology</i>	23
7.3 SYNCHRONIZATION	23
7.3.1 <i>CES Interworking Function- Synchronization Description</i>	25
7.3.2 <i>Synchronous IWF and Associated Tributaries</i>	27
7.3.2.1 Synchronous IWF and Tributaries	27
7.3.2.2 Synchronous IWF and Asynchronous Tributaries	27
7.3.3 <i>Asynchronous IWF and Associated Tributaries</i>	27
7.3.3.1 Asynchronous IWF, Asynchronous Tributaries.....	28
7.3.3.2 Asynchronous IWF, Synchronous Tributaries.....	28

7.3.4	<i>Synchronization Administration</i>	28
7.3.4.1	Single Service-Provider Owned Network.....	29
7.3.4.2	Multi Service-Provider Owned Network.....	31
7.3.4.3	Private (customer owned) Network.....	34
7.4	PERFORMANCE MONITORING AND ALARMS.....	35
7.4.1	<i>Facility Data Link</i>	35
7.4.2	<i>Alarms</i>	35
7.4.2.1	Unstructured Service.....	35
7.4.2.2	Structured Service.....	36
7.4.2.3	Buffer Underflow and Overflow.....	36
7.4.2.4	Alarms in CCS Signaling.....	36
7.4.3	<i>End-to-End Delay</i>	36
7.5	SERVICE IMPAIRMENT.....	36
7.5.1	<i>Errors within the MEN causing TDM service impairment</i>	37
7.5.1.1	Frame Loss.....	37
7.5.1.2	Frame Delay and Frame Jitter.....	37
7.5.1.3	Bit Errors.....	37
7.5.1.4	Frame Error Ratio and IWF behaviour.....	37
7.5.2	<i>Relationship to TDM service impairment metrics</i>	38
7.5.3	<i>Errored Seconds Requirement for PDH Circuits</i>	38
7.5.4	<i>Severely Errored Seconds Requirement for PDH Circuits</i>	39
7.5.5	<i>Service Impairments for SONET/SDH Circuits</i>	41
7.5.5.1	Performance Objectives for the SONET/SDH network.....	41
7.5.5.2	MEN Performance Objectives.....	42
7.5.5.3	Summary & Discussion.....	45
7.5.6	<i>Availability Requirements</i>	45
7.6	TDM SIGNALING.....	46
7.7	LOOPBACKS.....	46
7.7.1	<i>Provider Controlled Loopbacks</i>	46
7.7.2	<i>Customer Controlled Loopbacks</i>	47
7.8	PROTECTION.....	48
7.8.1	<i>Scenario 1 – dual unprotected services</i>	48
7.8.2	<i>Scenario 2 – dual protected services</i>	48
7.8.3	<i>Scenario 3 – Single protected service</i>	49
7.8.4	<i>Scenario 4 – Single to dual interface service</i>	49
7.9	SERVICE QUALITY.....	50
7.10	EFFICIENCY.....	50
7.11	NON-REQUIREMENTS.....	50
8.	CIRCUIT EMULATION SERVICE REQUIREMENTS.....	51
8.1	STRUCTURED DS1/E1 NX64 KBIT/S SERVICE.....	51
8.1.1	<i>TDM Framing</i>	51
8.1.2	<i>Timeslot Assignment</i>	51
8.1.3	<i>Multiplexing Support</i>	51
8.1.4	<i>Clocking</i>	52
8.1.5	<i>Jitter and Wander</i>	52

8.1.6	Facility Data Link.....	52
8.1.7	Bit Oriented Messages.....	52
8.1.8	Alarms.....	52
8.1.9	Signaling Bits.....	53
8.1.10	Lost and Out of Sequence Frames.....	53
8.1.11	Buffer Overflow/Underflow.....	53
8.2	DS1/E1 UNSTRUCTURED SERVICE.....	53
8.2.1	Framing.....	54
8.2.2	Clocking.....	54
8.2.3	Jitter and Wander.....	54
8.2.4	Facility Data Link.....	54
8.2.5	Alarms.....	54
8.2.6	Lost and Out of Sequence Frames.....	55
8.2.7	Buffer Overflow/Underflow.....	55
8.3	UNSTRUCTURED DS3/E3 SERVICE.....	55
8.3.1	Framing.....	55
8.3.2	Clocking.....	56
8.3.3	Jitter and Wander.....	56
8.3.4	Alarms.....	56
8.3.5	Lost and Out of Sequence Frames.....	56
8.3.6	Buffer Overflow/Underflow.....	57
8.4	SONET/SDH INTERFACES.....	57
8.4.1	Framing and Overhead Processing.....	57
8.4.2	Clocking.....	58
8.4.3	Pointer Adjustments.....	59
8.4.4	Jitter and Wander.....	60
8.4.5	Alarms.....	60
8.4.6	Buffer Overflow/Underflow.....	60
8.5	GENERAL REQUIREMENTS.....	60
8.5.1	Loopbacks.....	60
8.5.2	Frame Loss and Reordering.....	60
8.5.3	Efficiency.....	60
9.	MEN REQUIREMENTS.....	60
9.1	FRAME DELAY.....	60
9.2	ETHERNET FRAME JITTER.....	60
9.3	ETHERNET FRAME LOSS.....	60
9.4	NETWORK AVAILABILITY.....	60
9.5	BANDWIDTH PROVISIONING.....	60
10.	REFERENCES.....	60

List of Figures

Figure 1: TDM Line Service over Metro Ethernet Networks	11
Figure 2: Possible TDM Virtual Private Line Configurations	12
Figure 3: Example Multi-point to Point T-Line Multiplexed service	14
Figure 4: Multiplexing across a single Ethernet Virtual Connection.....	15
Figure 5: Handoff of a multiplexed trunk to an external network	16
Figure 6: Possible TDM Handoff Configurations	17
Figure 7: Customer Operated CES over a Metropolitan Ethernet Service (e.g. E-Line).....	17
Figure 8: Mixed-Mode Service.....	18
Figure 9: Functional Elements and Interface Types	19
Figure 10: Functional Elements of SONET/SDH emulation service.....	22
Figure 11: Interworking function direction	23
Figure 12: Timing distribution architecture showing clock domains	24
Figure 13: CES IWF Synchronization Reference Model.....	26
Figure 14: Synchronization Administration for a Single Service-Provider Network	30
Figure 15: Synchronization Administration for a Multi Service-Provider Network.....	31
Figure 16: Synchronization Administration for a Private Network	34
Figure 17: Allowed Frame Error Ratio to meet ES objectives	39
Figure 18: Relationship between Packing and FER for 0.01% SES.....	40
Figure 19: Relationship between Packing and FER for 0.01% SES based on 10^{-3} BER on end to end TDM data stream	41
Figure 20: Provider Controlled Loopback Points	47
Figure 21: Customer Controlled Loopback Points	47
Figure 22: Dual unprotected services	48
Figure 23: Dual protected services	49
Figure 24: Single protected service	49
Figure 25: Single to dual interface connection	49

List of Tables

Table 1: TDM Service Interfaces.....	20
Table 2: CES TDM Interface Definition	22
Table 3: Timing Distribution Definitions	24
Table 4: CE Synchronization modes and Expected Timing performance	25
Table 5: CES IWF Synchronization Definitions	26
Table 6: Timing Options per Synchronization Domain.....	28
Table 7: CES Services and supporting Synchronization Administration Models.....	29
Table 8: Timing Options Single-Service Provider Owned Network	30
Table 9: Timing Options Multi-Service Provider Owned Network.....	32
Table 10: Timing Options for a Private Network	34
Table 11: Example conversion from ES to FER for Ethernet Virtual Circuit	38
Table 12: Sparse FER objectives for MEN [G.826]	43
Table 13: Background FER and BER objectives for MEN [G.826].....	43
Table 14: Maximal FER accounted by SESR [G.826]	44
Table 15: MEN FER Requirements for SDH/SONET CES	45

1. Abstract

The emulation of TDM circuits over a Metro Ethernet Network (known as Circuit Emulation Services, or CES) is a useful technique to allow MEN service providers to offer TDM services to customers. This document outlines the types of the TDM services that can be offered over a MEN, and the requirements of such services. It covers both PDH services (e.g. Nx64 kbit/s, T1, E1, T3, E3) and SONET/SDH services (STS-1, STS-3, STS-3c, STS-12, STS-12c and European equivalents).

The document contains three sections:

- a set of service definitions for Circuit Emulation Services (CES) in the Metro Ethernet Forum context,
- a framework section explaining issues with the implementation of such services
- a set of requirements needed for providing such services in Metro Ethernet Networks (MEN).

Separate implementation agreements for PDH and SONET/SDH services will be produced which cover the implementation of these services in an inter-operable manner. This document is intended as a reference against which any Implementation Agreement can be compared to ensure that all the service requirements have been met.

2. Terminology

Term	Definition
AIS	Alarm Indication Signal
ANSI	American National Standards Institute
APS	Automatic Protection Switching
BER	Bit Error Ratio
BBER	Background Block Error Ratio
BLSR	Bi-directional Line Switched Ring
CAS	Channel Associated Signaling
CCS	Common Channel Signaling
CE	Customer Equipment
CES	Circuit Emulation Services
CR	Clock Recovery.
CRC	Cyclic Redundancy Check
CUET	Customer Unit Edge Terminal
DSTM	Derived System Timing Mode. The IWF system clock is derived from the incoming Ethernet frames.
DTM	Derived Timing Mode. The recovered service clock is derived from the incoming Ethernet frames.
E-Line	Ethernet Line Service
ECDX	Emulated Circuit De/Multiplexing Function
ECID	Emulated Circuit Identifier
EFT	Ethernet Flow Termination
ES	Errored Second
ESR	Errored Second Ratio

Term	Definition
ESF	Extended Super Frame
EVC	Ethernet Virtual Circuit
FDL	Facility Data Link
FER	Frame Error Ratio
HOVC	Higher Order Virtual Container
IA	Implementation Agreement
IETF	Internet Engineering Task Force
ITU-T	International Telecommunication Union – Telecommunication standardization sector
IWF	Inter-Working Function
LOH	Line OverHead
LOPS	Loss Of Packet Synchronization
LOS	Loss Of Signal
LOVC	Lower Order Virtual Container
LTE	Line Termination Equipment
MIB	Management Information Base
MEN	Metro Ethernet Networks
NE	Network Equipment
NNI	Network to Network Interface
PDH	Plesiochronous Digital Hierarchy. PDH refers to the DS1/DS2/DS3 and E1/E3/E4 family of signals
PE	Provider Edge
PLL	Phase Locked Loop
PRS	Primary Reference Source
PSTN	Public Switched Telephone Network
PWE3	Pseudo-Wire Emulation Edge to Edge (an IETF working group)
RDI	Remote Defect Indication
SDH	Synchronous Digital Hierarchy
SES	Severely Errored Second
SESR	Severely Errored Second Ratio
SF	Super Frame
SLA	Service Level Agreement
SLS	Service Level Specification
SONET	Synchronous Optical Network
SSM	Synchronization Status Message
TALS	TDM Access Line Service
TDM	Time Division Multiplexing (examples of TDM services include Nx64 kbit/s, T1, T3, E1, E3, OC-3, STM-1, OC-12, STM-4)
T-Line	TDM Line Service
TSP	TDM Service Processing

Term	Definition
UNI	User Network Interface
VC	Virtual Container
VT	Virtual Tributary
Mapper	A device or logic that implements a mapping function
Mapping	The process of associating each bit transmitted by the service into the SDH/SONET payload structure that carries the service. For example, mapping a DS1 service into SONET VT-1.5 / SDH VC-11 associate each bit of the DS1 with a location in the VT-1.5/VC-11
Multiplex	Transmit one or more channels over a single channel
Pointer	A part of the SDH/SONET overhead that locates a floating payload structure. Frequency differences between SDH/SONET network elements or between the payload and the SDH/SONET equipment can be accommodated by adjusting the pointer value.

3. Scope

The scope of this document is to address the particular requirements of transport over MEN for edge-to-edge-emulation of circuits carrying time division multiplexed (TDM) digital signals. It makes references to requirements and specifications produced by other standards organizations (notably the ITU, ANSI, IETF PWE3 and ATM Forum), and adapts these to address the specific needs of MEN. It is not in the scope of this document to duplicate any work of other related standardization bodies.

The document covers the definition of such services, a framework in which the service provision can be understood, and also the requirements for the defined services. The actual implementation of these services in an inter-operable manner will be the subject of separate Implementation Agreements, and hence is outside the scope of this document.

4. Compliance Levels

The key words “**MUST**”, “**MUST NOT**”, “**REQUIRED**”, “**SHALL**”, “**SHALL NOT**”, “**SHOULD**”, “**SHOULD NOT**”, “**RECOMMENDED**”, “**MAY**”, and “**OPTIONAL**” in this document are to be interpreted as described in [RFC 2119]. All key words must be use upper case, bold text.

5. MEF Document Roadmap

MEF draft specifications and the document roadmap are available in the members area on the Metro Ethernet Forum website at <http://www.metroethernetforum.net/>.

6. Circuit Emulation Service Definition

Ethernet CES provides emulation of TDM services, such as Nx64 kbit/s, T1, E1, T3, E3, OC-3 and OC-12, across a Metropolitan Ethernet Network. The object of this is to allow MEN service providers to offer TDM services to customers. Hence it allows MEN service providers to extend their reach and addressable customer base. For example, the use of CES enables metro Ethernet transport networks to connect to PBX's on customer premises and deliver TDM voice traffic along side of data traffic on Ethernet.

The CES is based on a point-to-point connection between two Inter Working Functions (IWF). Essentially, CES uses the MEN as an intermediate network (or 'virtual wire') between two TDM networks. This is handled as an application of the Ethernet service, using the interworking function to interface the applications layer onto the Ethernet services layer.

6.1 TDM LINE SERVICE (T-LINE)

The TDM Line (T-Line) service provides TDM interfaces to customers (Nx64 kbit/s, T1, E1, T3, E3, OC-3, OC-12 etc.), but transfers the data across the Metropolitan Ethernet Network (MEN) instead of a traditional circuit switched TDM network. From the customer perspective, this TDM service is the same as any other TDM service, and the service definition is given by the relevant ITU-T and ANSI standards pertaining to that service.

From the provider's perspective, two CES interworking functions are provided to interface the TDM service to the Ethernet network. The CES interworking functions are connected via the Metro Ethernet Network (MEN) using point-to-point Ethernet Virtual Connections (EVCs) as illustrated in Figure 1. (For the purposes of CES, the service provider owning the CES interworking functions is viewed as the "customer" of the MEN, providing the ability to use an Ethernet UNI, and the performance and service attributes associated with this concept).

The TDM Service Processor (TSP) block shown in Figure 1 consists of any TDM grooming function that may be required to convert the TDM service offered to the customer into a form that the CES IWF can accept (see section 7.2.2). For example, the TSP may be a Framer device, converting a fractional DS1 service offered to the customer into a Nx64 kbit/s service for transport over the MEN. The operation of the TSP is outside the scope of this document.

The TSP and the CES IWF may physically reside in the Provider Edge (PE) unit at the provider's nearest point-of-presence, or in a service provider owned box in a customer location (e.g. a multi-tenant unit). From the architecture perspective, there is no difference between these alternatives.

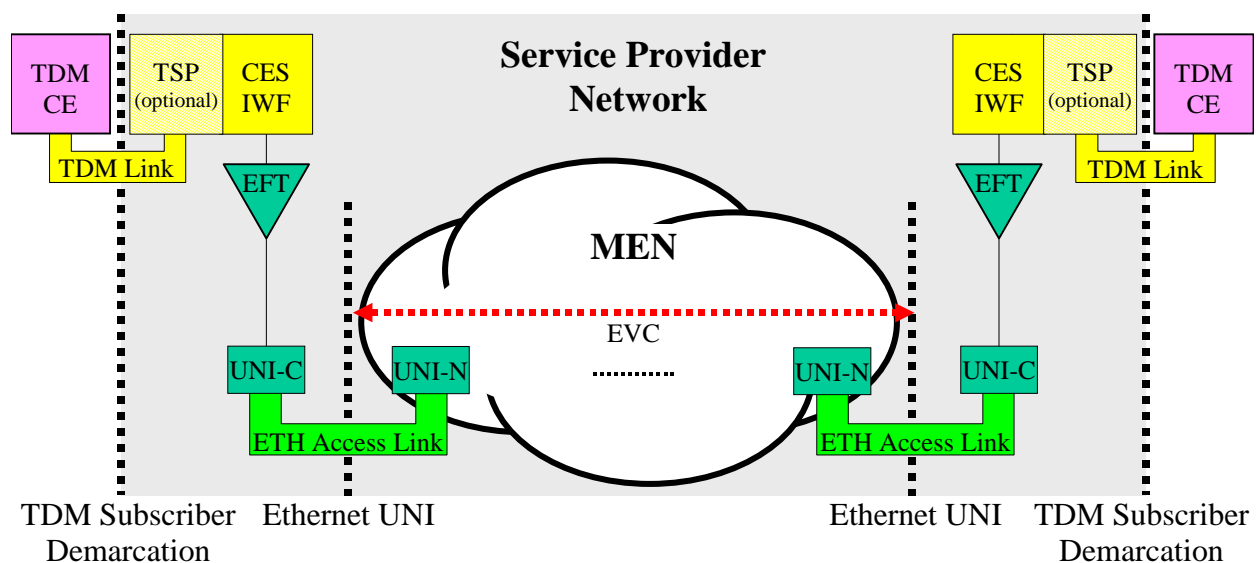

Figure 1: TDM Line Service over Metro Ethernet Networks

6.1.1 Operational Modes of a T-Line Service

The basic T-Line service is a point to point, constant bit rate service, similar to the traditional leased line type of TDM service. However, service multiplexing may occur ahead of the CES inter-working functions, (e.g. aggregation of multiple emulated T1 lines into a single T3 or OC-3 link), creating a multi-point to point or even a multi-point to multi-point configuration (see Figure 2 below).

This service multiplexing is carried out using standard TDM multiplexing techniques, and is considered as part of the TSP block, rather than the CES inter-working function. The TDM interface at the input of the CES inter-working function is the same as that output from the CES IWF at the opposite end of the emulated link. It is the TSP that may be used to multiplex (or demultiplex) that TDM service into the actual TDM service provided to the customer. This allows a TDM service to a customer to be provided as a collection of emulated services at lower rates.

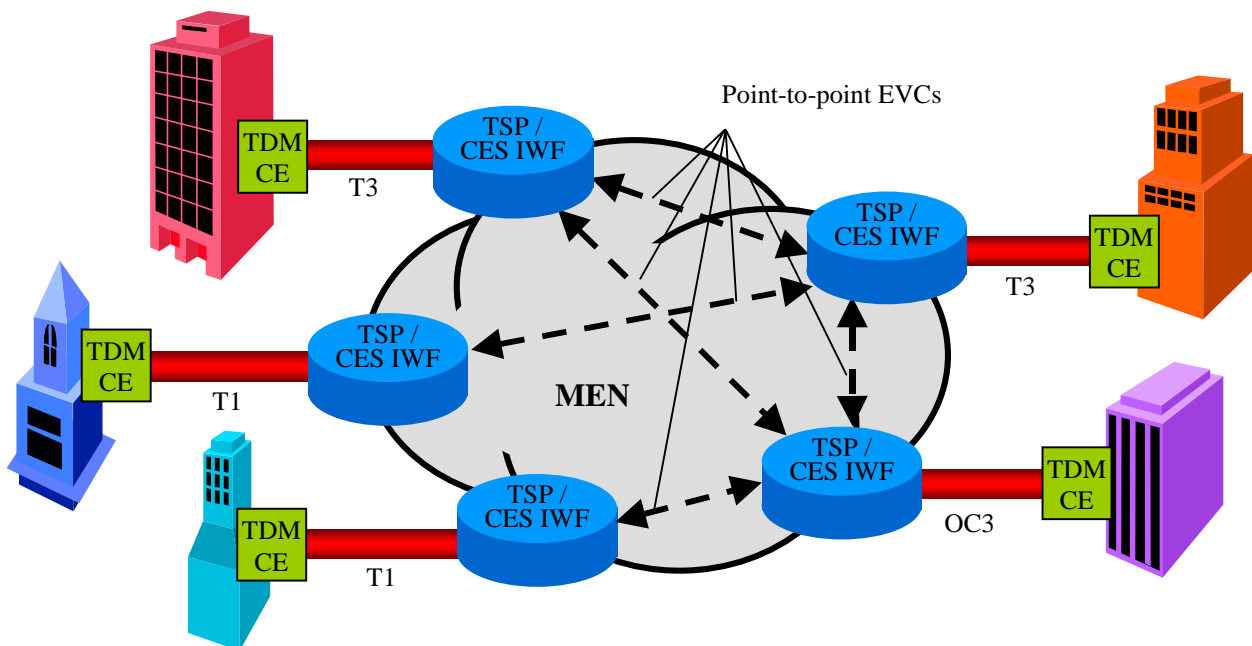

Figure 2: Possible TDM Virtual Private Line Configurations

Hence there are three possible modes of operation of a T-Line service:

- i. Unstructured Emulation mode (also known as “structure-agnostic” emulation)
- ii. Structured Emulation Mode (also known as “structure-aware” emulation)
- iii. Multiplexing mode

Modes (i) and (ii) are point-to-point connections. Mode (iii) permits multi-point-to-point and multi-point-to-multi-point configurations, although all of these modes are operated over simple point-to-point EVCs in the MEN.

6.1.1.1 Unstructured Emulation mode

In Unstructured Emulation Mode, a service is provided between two service-end-points that use the same interface type. Traffic entering the MEN on one end-point leaves the network at the other end-point and vice-versa.

The MEN must maintain the bit integrity, timing and other client-payload specific characteristics of the transported traffic without causing any degradation that would exceed the requirements for the given service as defined in the Requirements section of this document. All the management, monitoring and other functions related to that specific flow must be performed without changing or altering the service payload information or capacity.

Examples where unstructured emulation mode could be implemented are leased line services or any other transfer-delay sensitive (real time) applications. The specific transport rates and interface characteristics of this service are defined in the Requirements section of this document.

6.1.1.2 Structured Emulation mode

In Structured Emulation Mode, a service that is provided between two service-end-points that use the same interface type. Traffic entering the MEN on one end-point is handled as overhead and payload. The overhead is terminated at the near end point, while the payload traffic is transported transparently to the other end. At the far end point the payload is mapped into a new overhead of the same type as at the near end point.

The MEN must maintain the bit integrity, timing information and other client-payload specific characteristics of the transported traffic without causing any degradation that would exceed the requirements for the given service as defined in the Requirements section of this document. All the management, monitoring and other functions related to that specific flow must be performed without changing or altering the service payload information or capacity.

An example of such a service is the transport of OC-3 when the SOH is terminated at both ends and the STS-1 payloads are transported transparently over the MEN. A second example is a fractional DS1 service, where the framing bit and unused channels are stripped, and the used channels transported across the MEN as an Nx64 kbit/s service. The specific transport rates and interface characteristics are defined in the Requirements section of this document.

6.1.1.3 Multiplexing mode

In the multiplexing mode, multiple lower rate transparent services are multiplexed at a specific service-end-point of the MEN into a higher digital hierarchy. Similarly, a higher rate service may be de-composed into several lower rate services. For example, a customer may have several sites – a head office with a full DS1 connection, and several satellites with fractional DS1 connections, as shown in Figure 3. The same architecture can be used for multiplexing of other rate services, e.g. several full DS1 services onto a single DS3, or multiplexing of VT-1.5s into an STS-1. The specific transport rates and interface characteristics are defined in the Requirements section of this document.

Service multiplexing is typically performed in the TDM domain as part of a TSP, not in the Ethernet domain. A fractional TDM link going into the MEN comes out as a fractional TDM link, or at least as a payload containing solely that fractional link. Multiplexing and de-multiplexing is performed outside the CES IWF, as part of any native TDM signal processing, as shown in Figure 3. Therefore the *customer* service is multiplexed, but the *emulated* service (i.e. the service handled by the IWF) is structured.

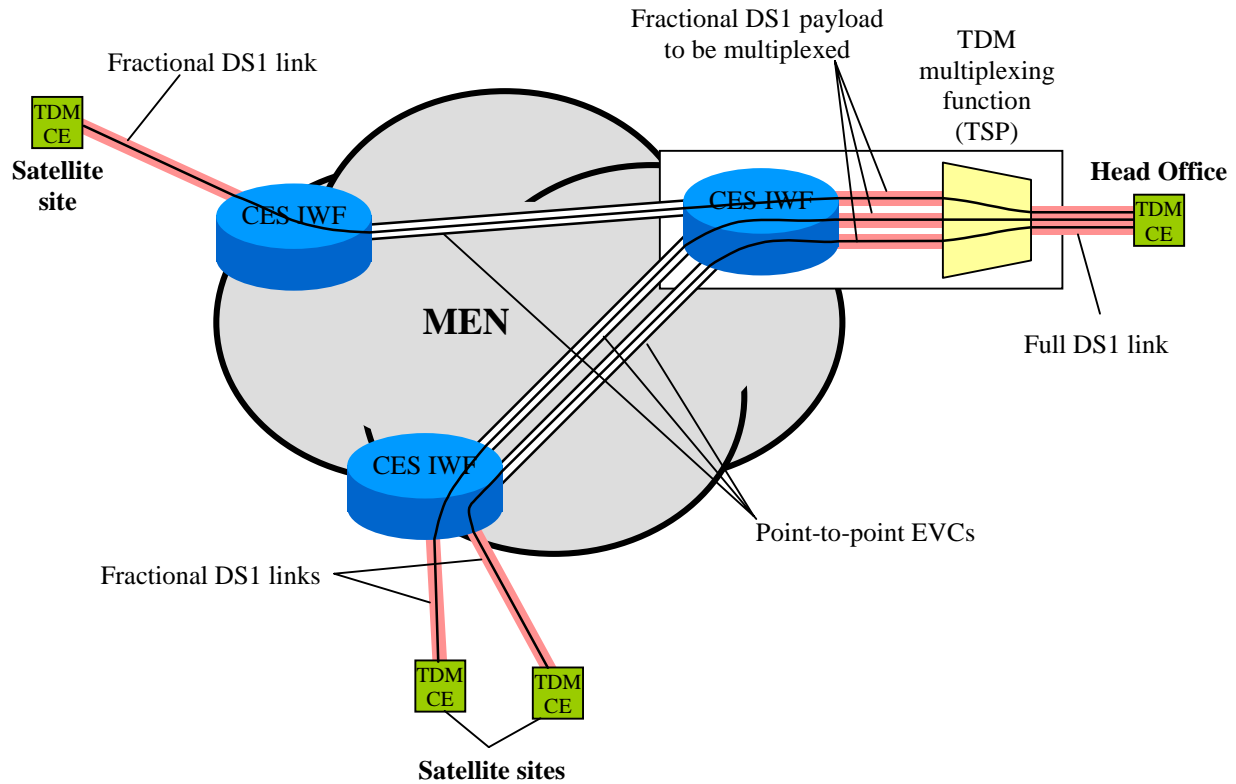

Figure 3: Example Multi-point to Point T-Line Multiplexed service

6.1.2 Bandwidth Provisioning for a T-Line Service

The Metro Ethernet service provider will need to allocate sufficient bandwidth within the network to carry the T-Line service. This may require very fine granularity of bandwidth provision to allow efficient allocation. For example, an $N \times 64$ kbit/s service may have very low bandwidth requirements where N is small. This could result in very inefficient provisioning if the smallest unit increment of bandwidth provision is 1 Mbit/s. The following sections outline three possible schemes to provision the bandwidth efficiently for low data rate CES.

6.1.2.1 Bandwidth allocation at 100 kbit/s granularity

The bandwidth required to be able to offer emulation of $N \times 64$ kbit/s services increases with N in steps of 64kbit/s, plus an overhead for encapsulation headers. Therefore, in order to be able to allocate MEN bandwidth efficiently for such services, the bandwidth needs to be provisioned in similar step sizes. It is recommended that to achieve reasonable efficiency, the granularity of service provisioning should be at 100 kbit/s or smaller.

However, most existing equipment only allows for bandwidth provision at multiples of 1 Mbit/s (or 1.5 Mbit/s for much SONET-based Ethernet equipment), so this fine level of granularity is not guaranteed to be available. Therefore alternative means of allocating bandwidth may need to be used to provide a reasonable level of efficiency, such as described in sections 6.1.2.2 and 6.1.2.3 below.

6.1.2.2 TDM multiplexing

Multiple TDM services between the same two IWFs may be multiplexed together in the TDM domain before being carried across the MEN. De-multiplexing at the far end is also accomplished in the TDM domain. For example, several fractional DS1 services could be multiplexed onto a single full DS1 link before transmission across the MEN. Bandwidth can then be provisioned for the full link, rather than individually for each fractional customer

service. Similarly, the same architecture can be used for multiplexing of other rate service, e.g. several full DS1 services onto a single DS3 or SONET link.

6.1.2.3 Ethernet multiplexing

Another alternative is to multiplex several circuits across a single Ethernet Virtual Connection, as shown in Figure 4.

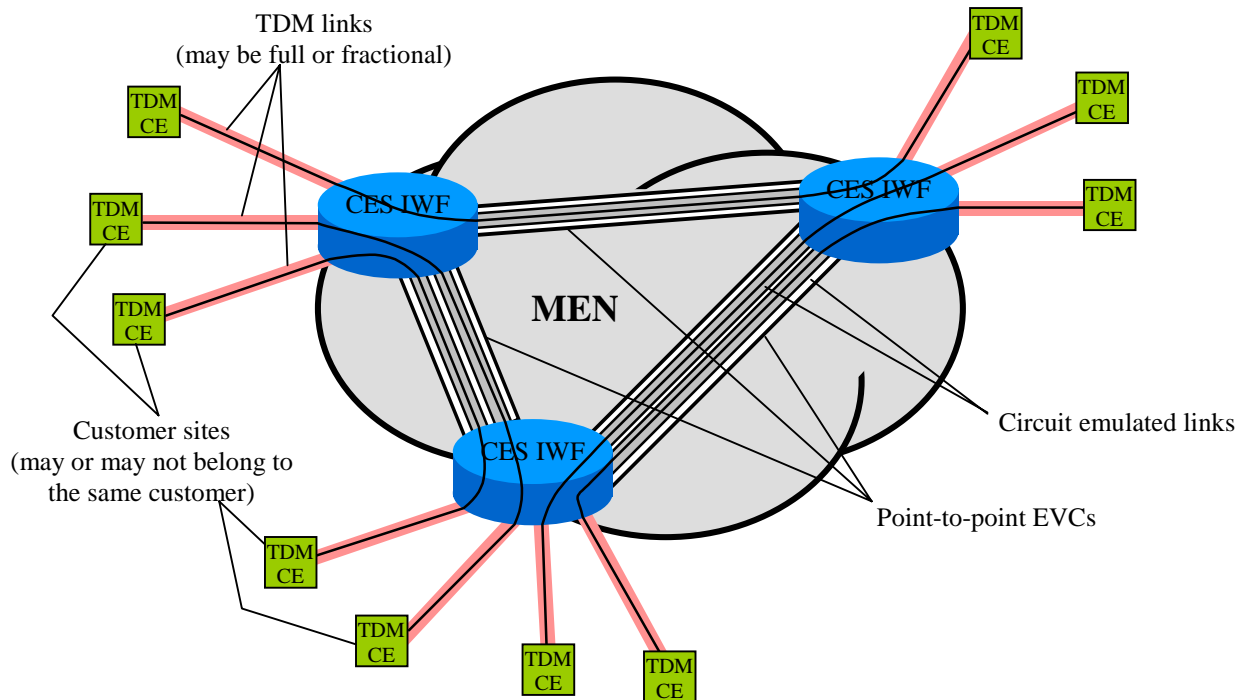

Figure 4: Multiplexing across a single Ethernet Virtual Connection

All TDM circuit emulation between any two given IWFs is handled across a single point-to-point EVC. Individual circuit emulated links are carried across that EVC using Ethernet multiplexing.. Customer separation is maintained using this multiplexing.

The total bandwidth of circuit emulation traffic between two points is known in the case of constant bit rate, always on service. Therefore the amount of traffic across that EVC is known and can be provisioned accordingly. This allows efficient bandwidth provisioning. For example, 5 fractional TDM services at 384 kbit/s could share a single 2 Mbit/s EVC, and don't have to be allocated 1 Mbit/s each.

6.2 TDM ACCESS LINE SERVICE (TALS)

The second type of TDM service that can be offered over Metropolitan Ethernet Networks is where the MEN service provider hands off one (or both) ends of the network to a second network (e.g. the PSTN). For example, Figure 5 shows the case where the customer interface is TDM, and the hand-off to an external network (in this case the PSTN) is via some form of TDM or SONET trunk line (e.g. OC-3). The prime use of this type of service is where the MEN is used as an access network onto the second network. With TALS service the customer-facing IWF can be located on the customer's site but is still under the control of the MEN operator.

Multiple customer services may be multiplexed up onto a single trunk to be handed off to the second network (Figure 6). As with T-Line service, this multiplexing is implemented using conventional TDM techniques in a native signal processing block. In some instances, both ends of the emulated TDM service may be within the service provider network, e.g. backhaul of ATM or SONET services.

As with T-Line service, the customer-facing TSP and CES IWF may physically reside in the Provider Edge (PE) unit at the provider’s nearest point-of-presence, or in a service provider owned box in a customer location (e.g. a multi-tenant unit). From the architecture perspective, there is no difference between these alternatives.

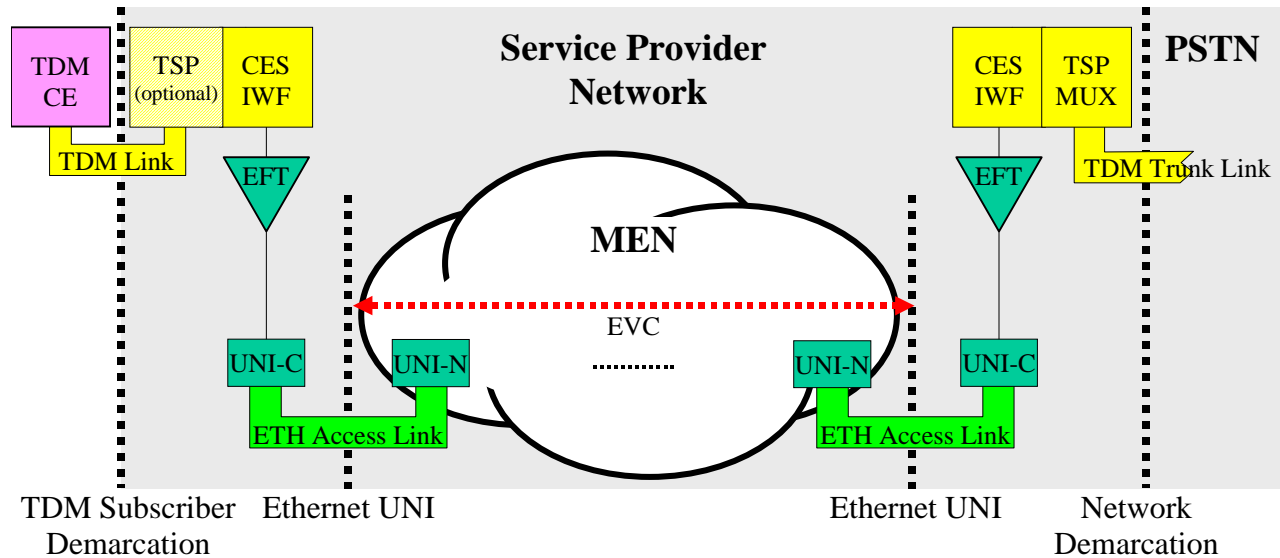

Figure 5: Handoff of a multiplexed trunk to an external network

6.2.1 Operational Modes of a TALS Service

The TALS service is essentially very similar to the multiplexed, multi-point-to-point T-Line service. The two services use the MEN in the same manner (see Figure 6). The only difference is that the final multiplexed service (e.g. OC-3) is handed off to another network rather than an end customer. As such, it may have some performance requirements deriving from the requirements of the second network not present in the T-Line service.

The MEN must maintain the bit integrity, timing and other client-payload specific characteristics of the transported traffic without causing any degradation that would exceed the requirements for the given service as defined in the Requirements section of this document. All the management, monitoring and other functions related to that specific flow must be performed without changing or altering the service payload information or capacity.

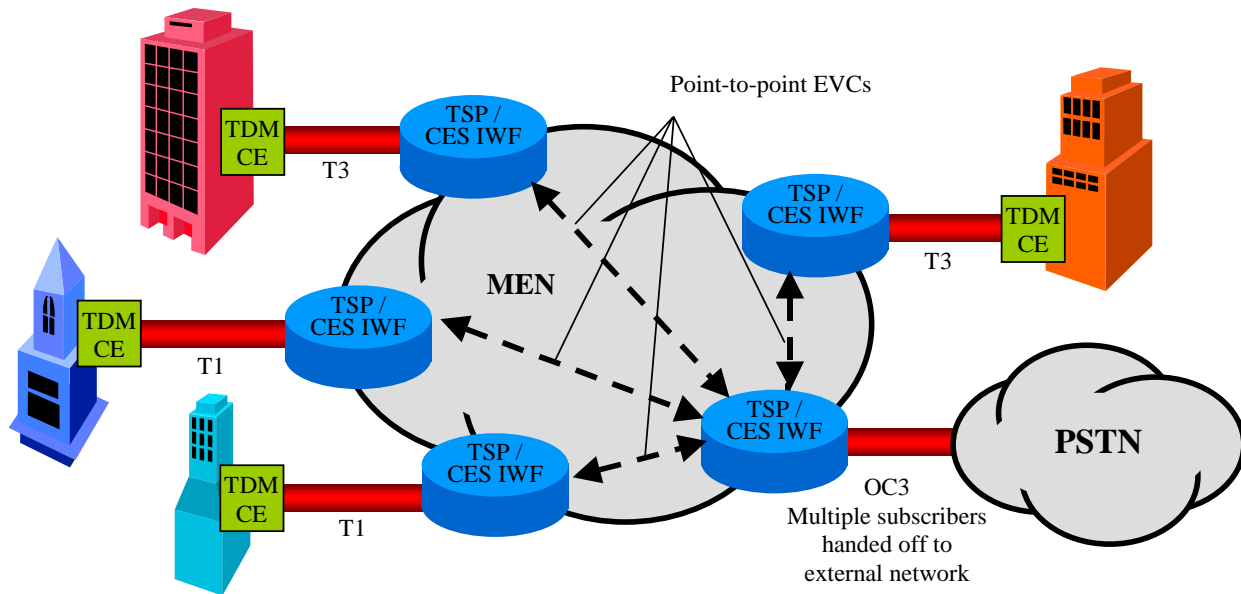

Figure 6: Possible TDM Handoff Configurations

6.3 CUSTOMER OPERATED CES

It is also possible for customers to operate the Circuit Emulation Service themselves across an E-Line service (see Figure 7). However, in order to operate CES at a reasonable level of quality, the service provider will need to offer a “premium SLA”, with tighter definitions of parameters such as packet delay, variation in packet delay, and packet loss. The requirements section of this document covers the parameters that need to be controlled, and the appropriate range of values over which CES can be operated with acceptable quality.

Some customers may choose to operate CES across a standard E-Line service with no special SLA for cost reasons. In this case, the level of quality experienced is entirely the customer’s own responsibility. Since from the service provider’s perspective this is purely an Ethernet service, **the definition of this service is considered to be outside the scope of this document**, other than to document possible parameters of a service level specification for CES-capable E-Line service.

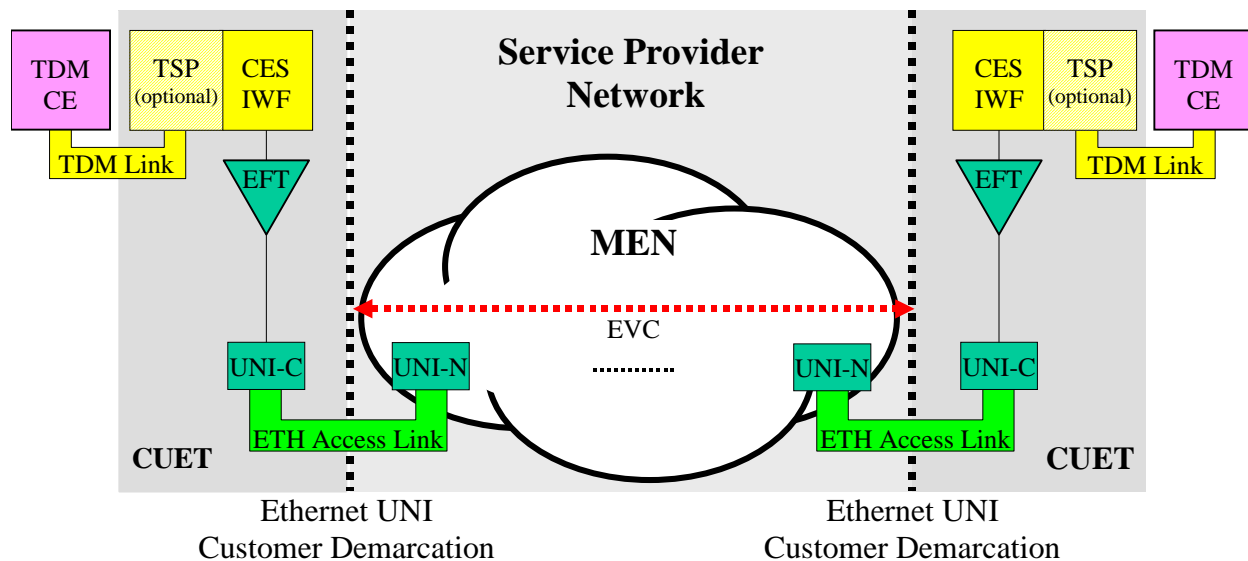

Figure 7: Customer Operated CES over a Metropolitan Ethernet Service (e.g. E-Line)

6.4 MIXED-MODE CES OPERATION

A further scenario is a “mixed mode service”, where the customer interface is Ethernet at one side, and TDM at the other. Therefore the customer is providing their own interworking function at one end of the service, and this must inter-operate with the service provider’s interworking function at the far end (Figure 8).

This service may be operated using the same methods as the other services described in this document. However, it may create significant issues as far as troubleshooting links between the service provider and the customer. For example it may be difficult to determine whether a fault is in the customer’s own equipment, or in the service provider’s equipment. Service providers offering mixed-mode services should be aware of the potential issues involved.

Resolution of these types of issues, as well as any operations and management issues involved with running between IWFs in different administrative domains are for further study. The MEF do not plan any further work on the definition of such a service at present.

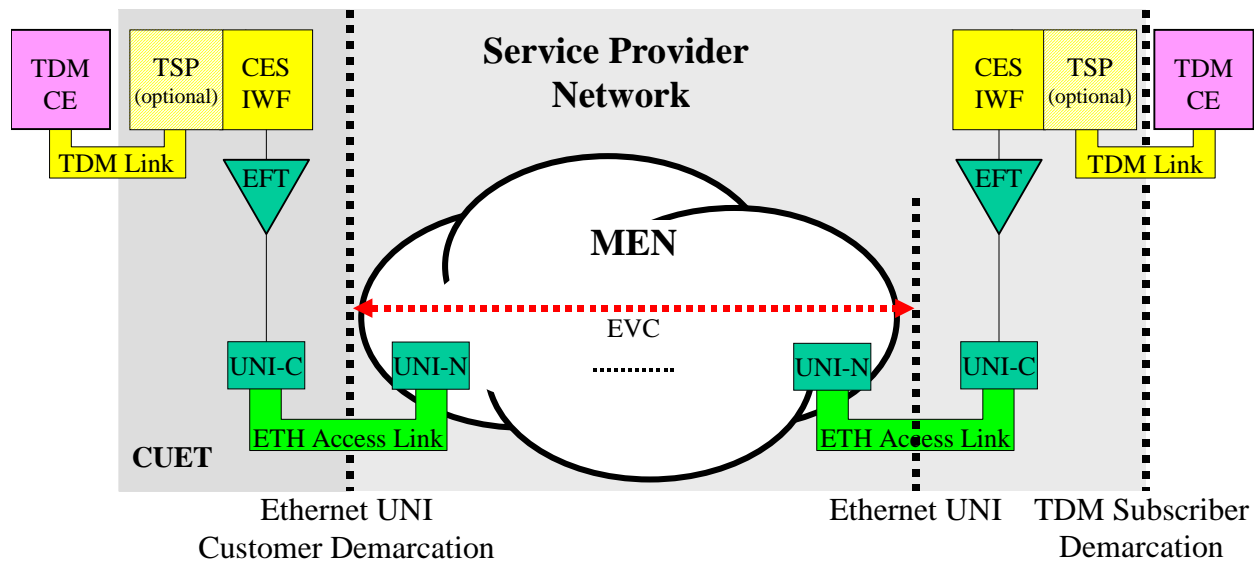

Figure 8: Mixed-Mode Service

7. Circuit Emulation Service Framework

This section is intended to provide a framework within which the actual requirements for the Circuit Emulation Service can be understood.

7.1 GENERAL PRINCIPLES

In most service provider networks, SONET/SDH has been used as the technology for transporting customers' PDH or SONET/SDH traffic. The purpose of the CES is to allow the MEN to serve not only as a transport of Ethernet and data services, but also as a transport of customer's TDM traffic.

The CES solution in the MEN should therefore make the MEN behave as a standard SONET/SDH and/or PDH network, as seen from the customer's perspective. The intention is that the CES customer should be able to use the same (legacy) equipment, regardless of whether the traffic is carried by a standard SONET/SDH or PDH network, or by a MEN using CES.

7.1.1 Use of External Standards

Section 3.2 of the "Architectural Principles of the Internet" [RFC 1958] states "If a previous design, in the Internet context or elsewhere, has successfully solved the same problem, choose the same solution unless there is a good technical reason not to."

Much of the material in the next two sections has been adapted from the ATM specification for circuit emulation [ATM CES], since this covers broadly similar requirements. It also references the various applicable standards from the ITU-T or ANSI for TDM services.

7.2 SERVICE INTERFACE TYPES

There are two basic service interfaces in the TDM domain. These are shown in Figure 9, and are defined as follows:

- 1) **TDM Service Interface:** The TDM service that is handed off to the customer or TDM network operator. TDM services fall into two categories, unstructured and structured.
- 2) **Circuit Emulation Service Interface (CES TDM Interface):** The actual circuit service that is emulated between interworking functions through the MEN.

For unstructured TDM service, the CES Interface carries all information provided by the TDM Service Interface transparently. The service is emulated in its entirety by the IWF, including any framing structure or overhead present.

For structured TDM service, the TDM service interface is operated on by the TSP (TDM Service Processor) to produce the service that is to be emulated across the MEN. A single structured TDM service may be decomposed into one or many CES flows, or two or more structured TDM services may also be combined to create a single CES flow.

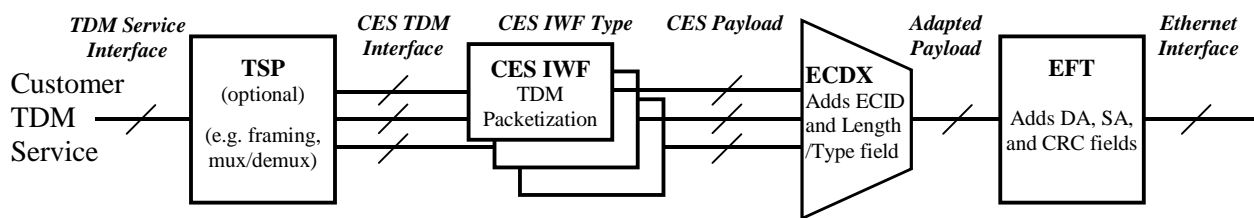

Figure 9: Functional Elements and Interface Types

7.2.1 Examples of TDM Service Interfaces

Table 1 shows examples of possible TDM service interfaces. These service interfaces are defined as standardized PDH, SONET or SDH interfaces.

Unstructured TDM services are either emulated as is by the CES IWF, or mapped by the TSP onto the CES interface without modifying their content. These services preserve the framing structure as well as SONET/SDH overhead as input to the TDM service interface. These services provide point-to-point connectivity across a MEN.

Structured services may be either demultiplexed into any of their defined service granularities or multiplexed with other structured TDM services. For example, an OC-3 structured service can be demultiplexed into three separate STS-1 signals. Each of these signals can then be circuit emulated by different IWF across the MEN to one or more service end-points. At these IWFs, these STS-1 can be reassembled with other STS-1s (from different originating services) to form an entirely new OC-3 signal (provided each originating site uses a PRS level clock). Structured service can be used to provide point-to-point, point-to-multipoint, and multipoint-to-multipoint TDM services.

TDM Service Interface	Unstructured TDM Service	Structured TDM Service	Structured TDM Service Granularity
DS1	Yes	Yes	Nx64 kbit/s
DS3	Yes	Yes	DS1, Nx64 kbit/s
E1	Yes	Yes	Nx64 kbit/s
E3	Yes	Yes	E1, Nx64 kbit/s, DS0
OC-1	Yes	Yes	STS-1, VT-1.5, VT-2
OC-3	Yes	Yes	STS-1, VT-1.5, VT-2
OC-3c	Yes	Yes	STS-3c
STM-1	Yes	Yes	VC-11 (DS1), VC-12 (E1), VC-3 (DS3, E3, other)
STM-1c	Yes	Yes	VC-4, VC-3, VC-11, VC-12
OC-12	Yes	Yes	VT-1.5 (DS1), VT-2 (E1), STS-1 (DS3, E3, other), STS-3c
OC-12c	Yes	Yes	STS-12c
STM-4	Yes	Yes	VC-11 (DS1), VC-12 (E1), VC-3 (DS3, E3, other), VC-4
STM-4c	Yes	Yes	VC-4-4c

Table 1: TDM Service Interfaces

7.2.2 TDM Service Processor (TSP)

The TDM Service Processor is defined as a function, operating in the TDM domain, that:

- a. modifies the bit rate or contents of the service to be emulated (e.g. overhead termination, removal of unused channels in a fractional service)
- b. multiplexes two or more TDM services into a single service to be emulated, and de-multiplexes the composite service into its component services at the remote end as required (e.g. multiplexing of several Nx64kbit/s services onto a larger Nx64kbit/s, or multiplexing of several DS1 services onto a DS3)
- c. transparently maps the TDM service onto a different service to be emulated (e.g. asynchronous mapping of a DS1 onto a VT-1.5)

It may make use of standard or proprietary techniques, and is not considered part of the inter-working function. Therefore the requirements in this document and the related implementation agreements do not cover the operation of any TSP function, which is considered part of an equipment vendors own value added domain.

By this definition therefore, a T1/E1 Framer would be considered a TSP (terminates the framing bits, breaks the service down into an Nx64kbit/s service), whereas an LIU would not (bit rate and data to be emulated are the same as in the TDM service offered to the customer). Another example of a TSP would be a DS1 to VT-1.5 mapper.

7.2.3 Circuit Emulation Inter-working Function (CES IWF)

Circuit Emulation Service is defined as an application service in terms of layered network model defined in the MEN Architecture framework document. It uses the MEN as an intermediate network (or “virtual wire”) between two TDM networks. The Circuit Emulation Interworking Function is therefore defined as the adaptation function that interfaces the CES application to the Ethernet layer.

The CES IWF is responsible for all the functions required for an emulated service to function, e.g. data packetization and de-packetization (including any padding required to meet the minimum Ethernet frame size), sequencing, synchronization, TDM signaling, alarms and performance monitoring. Listed in Table 2 are the defined interface types required to support circuit emulation over the MEN. These services are divided by payload type, CES Interface type, CES rate, and IWF type. These interface definitions are illustrated in Figure 9.

Payload Type	CES TDM Interface Type	CES Rate	IWF Type
PDH	NDS0	N x 64 kbit/s	NDS0-CE
	DS1	1.544 Mbit/s	DS1-CE
	E1	2048 kbit/s	E1-CE
	E3	34368 kbit/s	E3-CE
	DS3	44.736 Mbit/s	DS3-CE
SONET/SDH	STS-1	51.84 Mbit/s	STS-1-CE
	STS-3	155 Mbit/s	STS-3-CE
	STS-3c	155 Mbit/s	STS-3c-CE
	STM-1	155 Mbit/s	STM-1-CE
	STS-12	622.08 Mbit/s	STS-12-CE
	STS-12c	622.08 Mbit/s	STS-12c-CE
	STM-4	622.08 Mbit/s	STM-4-CE
SONET/SDH Tributary	VT-1.5	1.728 Mbit/s	VT-1.5-CE
	VT-2	2.176 Mbits	VT-2-CE
	VC-11	1.728 Mbit/s	VC-11-CE
	VC-12	2176 kbit/s	VC-12-CE
	VC-3	48384 kbit/s	VC-3-CE
	STS-1P	50.112 Mbit/s	STS-1P-CE
	STS-3P	150.336 Mbit/s	STS-3P-CE
	VC-4	150.336 Mbit/s	VC-4-CE
	STS-3cP	150.336 Mbit/s	STS-3cP-CE
	STS-12P	601.344 Mbit/s	STS-12P-CE
	STS-12cP	601.344 Mbit/s	STS-12cP-CE

Payload Type	CES TDM Interface Type	CES Rate	IWF Type
	VC-4-4	601.344Mbit/s	VC-4-4P-CE
	VC-4-4cP	601.344Mbit/s	VC-4-4cP-CE

Table 2: CES TDM Interface Definition

7.2.3.1 PDH Circuit Emulation Service

PDH emulation services provide transport of PDH services through the MEN. Managed by the IWF, as defined in Table 2, these services can be used to support structured or unstructured TDM service interfaces. As structured TDM services, the input TDM service can be demultiplexed into its service granularity as defined in Table 1. This service granularity includes DS0, Nx64 kbit/s, DS1, E1, DS3 or E3. Likewise, multiple structured TDM services can be multiplexed into a single service and circuit emulated across the MEN as this new service. For example, a multiple Nx64 kbit/s services can be multiplexed into a DS1 which is circuit emulated across the MEN and output as a DS1 structured service.. These interface rates and IWFs are presented in Table 2.

7.2.3.2 SONET/SDH Circuit Emulation Service

SONET/SDH emulation services provide transport of SONET/SDH services through the MEN. Managed by the IWF, as defined in Table 2, these services can be used to support structured or unstructured TDM service interfaces. As structured TDM services, the input TDM service can be demultiplexed into its service granularity as defined in Table 1. This service granularity includes STS-1, STM-1 or the appropriate virtual container. Likewise, multiple structured TDM services can be multiplexed into a single service and circuit emulated across the MEN as this new service. These interface rates and IWFs are presented in Table 2.

SONET/SDH emulation service provides emulation of the following services:

1. Higher order Virtual Container (HOVC): VC-3/STS-1, VC-4/STS-3c, VC-4-4c/STS-12c
2. Lower order Virtual Container (LOVC): VC-11/VT-1.5, VC-12/VT-2, none/VT-3, VC-2/VT-6, VC-3/none

SONET terminology refers to HOVC as Synchronous Payload Envelope (SPE) and for LOVC as Virtual Tributary (VT).

Figure 10 shows an example of the functional blocks used in SONET/SDH structured emulation service. For SONET/SDH interface, a SONET/SDH framer TSP is used to terminate and handle the section and line overheads. The SONET/SDH Virtual containers (SPEs) are extracted and passed to the SONET/SDH IWF(s). Each virtual container (SPE) can be sent to a different destination IWF. The ECDX and EFT are used to add the required multiplexing and Ethernet headers and trailers as described in Figure 9. For PDH interfaces, a SONET/SDH mapper TSP is used to map the PDH signal (T1/E1/T3/E3) into SONET/SDH virtual containers (SPE/VT). Each virtual container can be sent to a different destination IWF, and either groomed to a SONET/SDH interface or mapped back to a PDH interface.

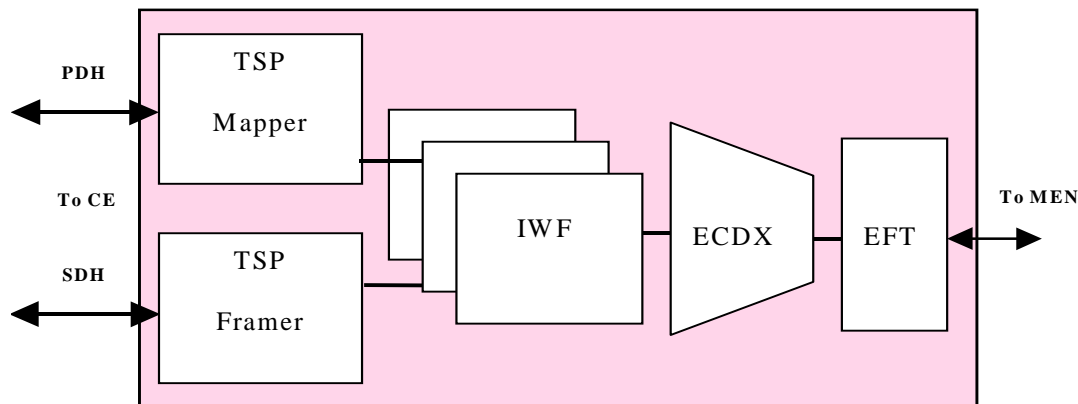

Figure 10: Functional Elements of SONET/SDH emulation service

7.2.4 Emulated Circuit De/Multiplexing Function (ECDX)

The Emulated Circuit De-multiplexer (ECDX) is a function, operating in the packet domain, that:

- a. Selects one (or more) IWF as the final destination of each Ethernet frame received from the MEN based on an Emulated Circuit Identifier (ECID) attribute within the frame header.
- b. Prepends an ECID attribute for each Ethernet frame sent to the MEN to allow circuit de-multiplexing on the MEN egress.
- c. Assigns the length/type field to each Ethernet frame sent to the MEN.

By this definition, equipment supporting 8 DS1 TDM service interfaces would be able to multiplex 8 DS1 interface onto a single EVC. Each emulated circuit would be identified by a unique ECID attribute. The ECDX function would examine the ECID attribute of received Ethernet frames and compare it to its local ECID to IWF association. According to the look-up result the ECDX would pass the circuit emulation payload to the relevant IWF for processing.

7.2.5 Ethernet Flow Termination Function (EFT)

A termination function is defined as: “A transport processing function which accepts adapted characteristic information from a client layer network at its input, adds information to allow the associated trail to be monitored (if supported) and presents the characteristic information of the layer network at its output(s) (and vice versa)”

In the context used here, an Ethernet Flow Termination function takes an adapted payload from the ECDX (the MAC client information field), along with a Length/Type attribute describing it as CES payload. It adds the MAC Destination and Source addresses, and finally the frame check sequence.

In the CE-bound direction, the EFT takes in an Ethernet frame from the MEN. It determines whether it contains CES payload from the Length/Type field, and forwards it to its associated ECDX function, for passing to the appropriate CES IWF.

7.2.6 Direction terminology

For each direction of an emulated circuit, there is a pair of CES interworking functions. The *MEN-bound IWF* handles the packetization of the TDM data, encapsulation into Ethernet frames and forwarding into the Ethernet network. The corresponding *CE-bound IWF* extracts the TDM data from the Ethernet frames, and recreates the TDM service. Each direction of the service is handled separately by second pair of IWFs. Hence for a given MEN-bound IWF, the corresponding CE-bound IWF is at the other side of the MEN.

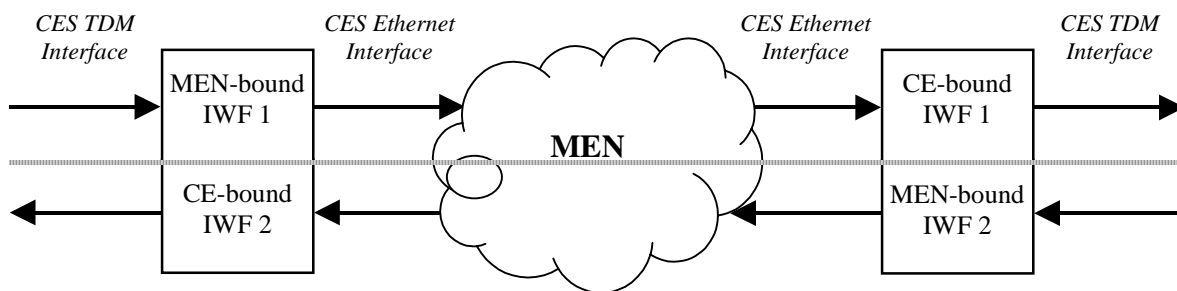

Figure 11: Interworking function direction

7.3 SYNCHRONIZATION

Figure 12 shows the synchronization domains needed to support CES:

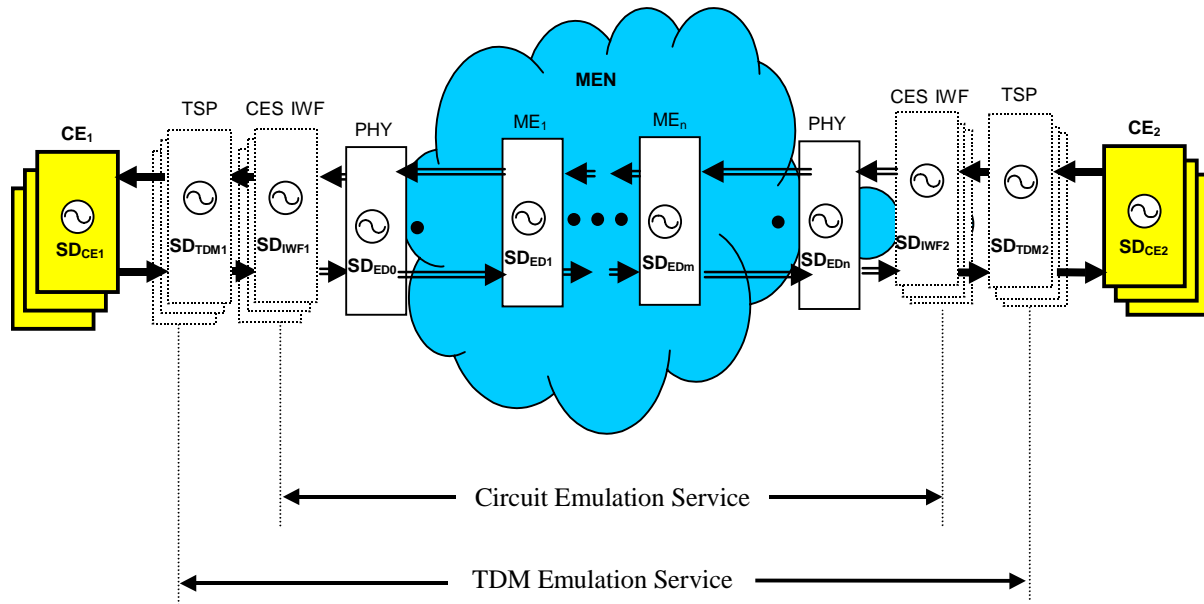

Figure 12: Timing distribution architecture showing clock domains

The following notations are used in Figure 12:

Attribute	Description
CES IWF	Circuit emulation service interworking function.
CE _n	Customer edge devices terminating/originating TDM circuits
TSP	The TDM Service Processor performs all TDM functions necessary to support structured or unstructured TDM emulation service. These functions are performed in the TDM domain using standardized techniques.
ME _n	Metro Ethernet devices providing Circuit Emulation Service transport in the MEN
PHY	Physical interface terminating Ethernet traffic
→	The TDM-end service circuits
⇒	The CES IWF providing edge-to-edge-emulation for the TDM circuit
SD _{Edn}	The synchronization domain used by Ethernet network elements (NEs) in the MEN cloud. This timing information is used to transport packets between Ethernet NEs providing the CES. Since each of these devices operates independently, the synchronization mode of each device must be provisioned separately. Typical timing modes include line, external and free-run.
SD _{IWFn}	The synchronization domain used by CES IWF. This timing is used to transport the circuit emulated service across the MEN. This synchronization domain is specific to the CES interface types as shown in Table 2 (CES Interface Definition). Details of this synchronization domain are contained in the IA reference as shown in Table 2 (CES Interface Definition)..
SD _{TDMn}	The synchronization domain used by the TSP. This timing is used to transport TDM signals between the TSP and CE. This synchronization domain supports through timing mode.
SD _{Cen}	The synchronization domain used by the CE devices to establish the TDM service clock. This timing is used to transport TDM signals between the CE and the TSP. This synchronization domain supports external, line, or free-run timing modes.

Table 3: Timing Distribution Definitions

One of the objectives of edge-to-edge-emulation of a TDM circuit is to preserve the service clock with a performance level as specified in the relevant Implementation Agreements. For example, the performance objective could be to meet the G.823 Traffic Interface specification. The service clock can be either generated at a CE via external timing mode, or recovered from the TDM bit stream via line/loop timing mode. It should be noted that loop timing mode is a recovery process where timing is extracted from only one available input bit stream. Line timing mode is a recovery process where timing is extracted from one of several input bit streams. Since the number of available timing inputs is based on network design and system architecture, this document will use “line timing” when describing timing modes where either line or loop timing are used.

Typical timing modes for a point-to-point CES connection are shown in Table 4. These timing modes are defined in [T1.101] and [G.812].

Timing Option	CE1 Timing Mode	CE2 Timing Mode	Comments
1	External to PRS traceable source	External to PRS traceable source	CE1 and CE2 will operate in a Plesiochronous mode. If connected to other TDM circuits (in other synchronization domains) network slip-rate objectives will be met.
2	External to PRS traceable source	Line timing mode	CE2 will have the same average frequency as CE1. If connection to other TDM circuits (in other synchronization domains) network slip-rate objectives will be met.
3	Line timing mode	External to PRS traceable source	CE1 will have the same average frequency as CE2. If connection to other TDM circuits (in other synchronization domains) network slip-rate objectives will be met.
4	Free-run mode	Line timing mode	CE2 will have the same average frequency as CE1. If connection to other TDM circuits (in other synchronization domains) undesirable slip performance may result.
5	Line timing mode	Free-run mode	CE1 will have the same average frequency as CE2. If connection to other TDM circuits (in other synchronization domains) undesirable slip performance may result.
6	Free-run mode	Free-run mode	CE1 and CE2 synchronization domains will operate independently. TDM data will experience slips between CE1 and CE2 and TDM circuits in other synchronization domains.

Table 4: CE Synchronization modes and Expected Timing performance

When the TDM circuit is transported via CES, this continuous signal is broken into packets at the MEN-bound IWF of the CES connection and reassembled into a continuous signal at the CE-bound IWF of the CES connection. In essence, the continuous frequency of the TDM service clock is disrupted when the signal is mapped into packets.

In order to recover the service clock frequency at the egress of the CES connection, the interworking function must employ a process that is specific to the CES interface type. The description and requirements of the IWF service clock recovery are contained in the Implementation Agreement for that service.

7.3.1 CES Interworking Function- Synchronization Description

The synchronization block diagram for the CES Interworking function is shown in Figure 13.

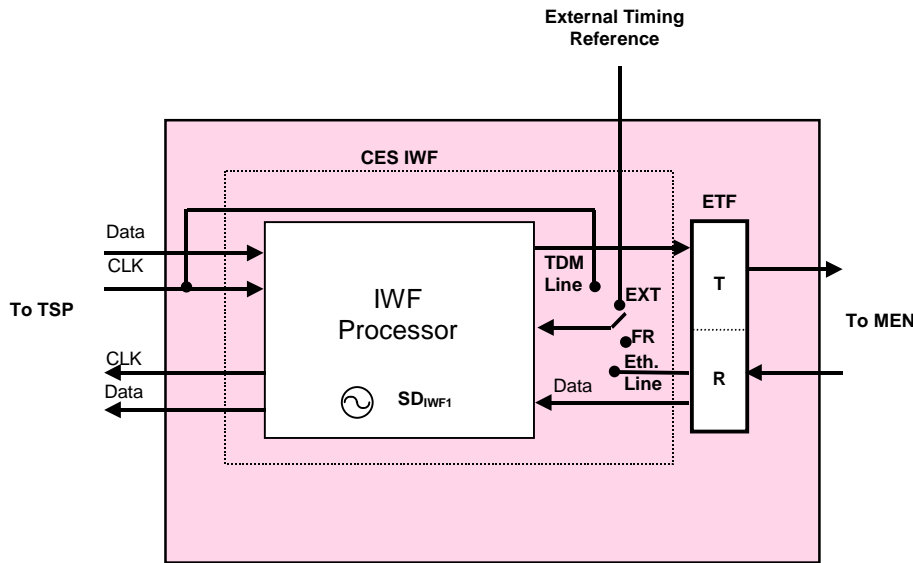

Figure 13: CES IWF Synchronization Reference Model

The following notations are used in Figure 13:

Attribute	Description
IWF Processor	Performs all data, addressing and timing functions necessary to support circuit emulation over the MEN.
TDM Line	A line timing option may be used to provide the IWF with a timing reference. TDM Line timing will extract timing from either the TDM service SD_{TDM} .
Ethernet Line	Ethernet Line timing will extract timing from either the MEN SD_{ED} or from the arriving Ethernet frames.
EXT	An External timing option may be used to provide the IWF with a timing reference
FR	An internal timing reference may be used to provide the IWF with a timing reference. This internal timing reference may either be a free-running oscillator or an oscillator in holdover mode.
SD_{IWF}	The synchronization domain for the IWF. The definition and requirements for the SD_{IWF} may be found in the IA for the specific IWF per table 2 (CES Interface Definition)
ETF	Physical interface terminating Ethernet traffic

Table 5: CES IWF Synchronization Definitions

The main goal of the CES IWF is to preserve the service clock of the TDM service through the MEN. The CES IWF must preserve the service clock to the accuracy defined in section 7 of this document even under the levels of MEN jitter defined in section 9.2.

The operation and definition of the interworking functions are specific to the CES interface type as shown in Table 2 (CES Interface Definition Table). Specific information about operation and requirements for specific interworking functions is contained in the implementation agreements as indicated in Table 2 (CES Interface Definition Table).

The IWF can use a variety of timing inputs to use as a reference for service clock recovery. A list of the five available timing inputs used by the CES IWF are shown below:

1. **Line timing (from the CE)** – This mode is used to recover timing from a CE. In order for this timing mode to PRS traceable, the CE must be provisioned to recover and transmit PRS traceable timing. Line timing should be used if synchronization messaging is available (e.g., SONET or SDH line timing sources).

2. **Line timing (from the MEN)** – This mode is used to recover timing from the MEN. In order for this timing mode to be PRS traceable, the adjacent Ethernet NE (in the MEN) must be provisioned to recover and transmit PRS traceable timing. Line timing should be used if synchronization messaging is available (e.g., SONET or SDH line timing sources). Line timing can also include deriving a clock from incoming Ethernet packets (e.g. use of adaptive or differential clock recovery methods).
3. **External Timing** – This mode is used to recover PRS traceable timing from a co-located building integrated timing supply (BITS). Timing is typically sent to the TSP/IWF as an all ones DS1 or E1 with framing. Synchronization status messaging (SSMs) may also be transmitted over the DS1 link using a “blue signal” (all ones without framing) or via SSMs on the ESF data link as defined by ANSI T1.101.
4. **Free-Run** – This mode is considered a standalone mode. It should only be used when a suitable line or external timing reference is not available. The frequency and stability of this timing mode is determined by the TSP/IWF’s internal oscillator.
5. **Holdover** – This mode is usually considered a backup or protection timing mode. Holdover mode may be initiated when the external or line timing references have been lost due to a failure. This failure is indicated to the CES IWF via a loss of frame (LOF), loss of signal (LOS) or SSM indication. Unlike free-run, this timing mode relies on the TSP/IWF’s internal oscillator that has been trained by an external timing reference (e.g., PRS traceable timing source). See ANSI T1.101 for performance specifications of this and other timing modes. Holdover may also be used when there is a cessation of activity on the MEN-bound TDM interface (e.g. due to the normal operation of a variable bit rate IWF).

7.3.2 Synchronous IWF and Associated Tributaries

Synchronous IWFs require that the IWF synchronization domain (SD_{IWF}) at both the MEN-bound IWF and the CE-bound IWF use common clock synchronization (e.g. timing that is traceable to the same physical clock).

Unless specific mechanisms have been put in place to ensure that a common clock is distributed between both IWFs, it should be assumed that the IWFs are NOT synchronous. It is not reasonable to assume the IWFs have suitable clocking information unless it has been specifically provided for.

Tributaries to the IWFs consist of those TDM services that originate at the CE and are terminated at the IWF. The service clock of each tributary may be either synchronous (PRS traceable) or asynchronous (not PRS traceable).

7.3.2.1 Synchronous IWF and Tributaries

Synchronous IWF: In this scenario, the synchronization domains at the MEN-bound and CE-bound IWFs (SD_{IWF}) use common clock synchronization (e.g. timing that is traceable to the same physical clock).

Synchronous Tributary: The synchronization domains of the CE devices (SD_{Cen}) require that at least one of the CE devices use external timing that is PRS traceable. The other CE, in the CES connection, may be either line-timed to the originating CE or externally-timed to a PRS traceable source.

7.3.2.2 Synchronous IWF and Asynchronous Tributaries

Synchronous IWF: In this scenario, the synchronization domains at the MEN-bound and CE-bound IWFs (SD_{IWF}) use common clock synchronization (e.g. timing that is traceable to the same physical clock).

Asynchronous Tributary: The synchronization domains of the CE devices (SD_{Cen}) require that at least one of the CE devices be externally-timed to a non-PRS traceable source or use its internal free-running oscillator. The other CE can be either line-timed, be externally-timed, or operate on its internal free-running oscillator. Of these options, only the line-timed option will provide slip-free performance under non-fault conditions (see Table 4).

7.3.3 Asynchronous IWF and Associated Tributaries

In the Asynchronous network, the synchronization domains of all IWFs (SD_{IWF}) do not use a common source of timing. For example, the IWFs may receive plesiochronous timing as defined in [T1.101]. Tributaries to the IWF

consist of TDM services that originate at the CE and are terminated at the IWF. At the TDM Service Processor, the service clock of each TDM tributary (SD_{Cen}) is terminated. This service clock will be used to support any functions necessary to create structured or unstructured TDM emulation services. After these services are created, the service clock along with the TDM data are then input to the CES IWF.

7.3.3.1 Asynchronous IWF, Asynchronous Tributaries

Asynchronous IWF: In this scenario, not all of the synchronization domains of the IWF devices (SD_{IWF}) use common clock synchronization (e.g. timing from the same physical clock). Timing distribution for the IWF may be configured with each either line-timed to the MEN, line timing to a dedicated CE, or externally-timed to a PRS traceable source.

Asynchronous Tributary: The synchronization domains of the CE devices (SD_{Cen}) require that at least one of the CE devices be externally timed to a non-PRS traceable source or use its internal free-running oscillator. The other CE can be either line-timed, externally-timed, or operate on its internal free-running oscillator. Of these options, only the line timed option will provide slip-free performance under non-fault conditions (see Table 4).

7.3.3.2 Asynchronous IWF, Synchronous Tributaries

Asynchronous IWF: In this scenario, not all of the synchronization domains of the IWFs (SD_{IWF}) use common clock synchronization (e.g. timing from the same physical clock). Timing distribution for the IWFs may be configured with each either line timed to the MEN, line-timing to a dedicated CE, or externally-timed to a PRS traceable source.

Synchronous Tributary: The synchronization domains of the CE devices (SD_{Cen}) require that at least one of the CE devices use external timing that is PRS traceable. The other CE, in the CES connection, may be either line-timed to the originating CE or externally-timed to a PRS traceable source.

7.3.4 Synchronization Administration

Proper synchronization administration is crucial to support the transport of TDM emulation and circuit emulation services. Each synchronization domain in the CES needs to be considered and provisioned independently. Table 6 provides a summary of typically available options per synchronization domain.

CE	IWF	TSP	MEN
SD_{CE}	SD_{IWF}	SD_{TDM}	SD_{ED}
External	Per IA	External	PRS Traceable
Line		Line – CE	Non-PRS Traceable
Free-Run		Line-MEN Free-Run	

Table 6: Timing Options per Synchronization Domain

Proper synchronization administration begins with the following concepts:

- **Separate and Diverse** – Synchronization equipment and paths should follow separate and diverse paths. This reduces the chance that a single point of failure will cause service disruption. This philosophy extends to equipment placement, cable routing, powering sources and network element configuration.
- **Synchronization Trail** – All synchronization flows have a defined source and end. The context of this flow is based on a logical flow rather than a topology (which could be linear, ring, mesh, or a combination of these). The flow can even span multiple transport technologies including Ethernet, SONET and SDH. The source of a synchronization trail should be from an independent reference that is either PRS traceable or from a free-running oscillator. The synchronization trail ends on a specific device that does not further propagate the source timing information. Such a terminating device is necessary to prevent timing loops, which will cause transport errors in the physical layer. Intermediate equipment in the synchronization trail can use timing information

derived from the source in a daisy-chained configuration. It should be noted that upstream timing events (protection switching, holdover events, clock failures, etc..) will be propagated to downstream equipment in this configuration. For these cases, downstream equipment will need to have pre-determined fault modes to deal with these circumstances when they arise. Such fault modes may include protection switching to use a different line-timed reference or entry into holdover.

- **Service Clock Preservation** – The service clock is defined at the timing source used to generate the client signal. In a CES transport network, the service clock frequency must be preserved in order to have error-free transport of the physical layer. That is to say that the average bit rate of the transmitting and receiving Customer Edge devices must be the same. Otherwise, the transport capability of the CES will be compromised.
- **Synchronization Traceability** – In synchronization network planning, it is important to know where a timing source originates, how it flows in the network, and its quality. The concept of traceability provides the answers to these quantities. Synchronization flows can be described in terms of source traceability. That is to say, that timing originates at a physical location and is used by equipment in a synchronization trail either by external or line timing options. Common clock distribution is an example of a source traceable clock scheme. In the case of frequency traceability, the quality of a timing signal can be specified. For example, the frequency of synchronization sources may be specified as being PRS traceable or accurate to within 1 e-11 or (.00001 parts per million). Plesiochronous clock distribution is an example of a frequency traceable clock scheme.

Three synchronization administration models are presented in the following sections. These models have been chosen to illustrate how they may be used to accommodate the CES definitions presented in Section 6. These models are:

- **Single Service Provider Owned Network** – A single service provider controls the entire transport synchronization trail. The service synchronization trail is separate.
- **Multi-Service Provider Owned Network** – Multiple service providers control the transport synchronization trail. The service synchronization trail is separate.
- **Private (customer owned) Network** – A customer controls the entire transport and service synchronization trails.

Table 7 summarizes these synchronization administration models and shows how they map to the CES service definitions of Section 6.

CES Service	Sync Admin Model	Notes
TDM Virtual Private Line Service	Single Service Provider Model	Can also be used with Private Network model.
TDM Access Line Service	Single Service Provider Model	Handoff to PSTN does not retime the payload (DS1 or DS3). Therefore, there is no new sync trail.
Customer operated CES over Metro Ethernet Service	Multi-Service Provider Model	IWF at CES egress may be owned by a different service provider.

Table 7: CES Services and supporting Synchronization Administration Models

7.3.4.1 Single Service-Provider Owned Network

The synchronization administration for a single service-provider owned network is illustrated in Figure 14.

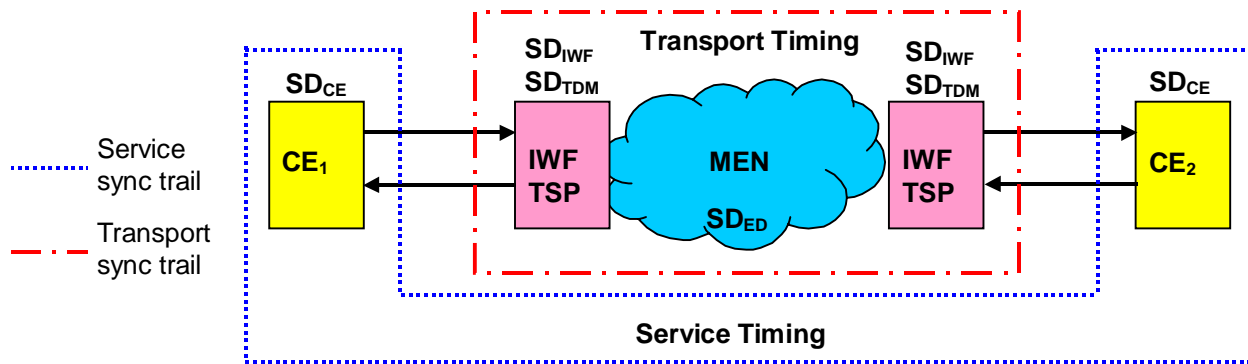

Figure 14: Synchronization Administration for a Single Service-Provider Network

A summary of available timing options for the Single-Service Provider owned network is presented on Table 8.

Device	Timing Domain	Timing Options	Notes
CE	SD _{CE}	External	Customer Option: Requires a collocated BITS or SSU to supply a timing input to the CE. May be used as a source for the synchronization trail.
		Line	Customer Option: May be used at the end of a synchronization trail.
		Free-Run	Customer Option: May be used as the source for the synchronization trail.
IWF	SD _{IWF}	See IA	Service Provider Option: Timing recovery for CES IWF must match the IWF type. Details can be found in the IA as specified on Table 2 (CES Interface Definition).
TSP	SD _{TDM}	External	Service Provider Option: Requires a collocated BITS or SSU to supply a timing input to the PE.
		Line – CE	Not Used since CE and TSP are on different synchronization trails.
		Line-MEN	Service Provider Option: Used if the IWF can provide timing. Consistent with the service needs of the TSP. Options and capabilities for a specific IWF is specified per the appropriate IA.
		Free-Run	Service Provider Option: Used only if there is no suitable line or external timing source.
MEN	SD _{ED}	PRS Traceable	Service Provider Option: Requires that all elements use PRS traceable timing
		Non-PRS Traceable	Service Provider Option: Requires that one or more elements not use PRS traceable timing.

Table 8: Timing Options Single-Service Provider Owned Network

Note that in the Single-Service Provider configuration, the synchronization trails for service-timing and transport-timing are separate. Separation of these synchronization trails is typically done for administrative and liability reasons. An end customer will not be able to manage a service provider’s timing equipment. Likewise, a service provider would typically not use timing from a CE due to the reliability and liability issues associated with a single point of failure.

Separate synchronization trails also means that the physical timing source used to derive the service clock is not the same as that used in the transport network (TSP/IWF and MEN). This is not to say that the source for the service and transport cannot be PRS traceable, simply that one is not the source for the other.

7.3.4.1.1 Service Timing – Single Service Provider Network

The Customer Edge synchronization domain (SD_{CE}) is owned and maintained by the customer. Timing for the CE (SD_{CE}) requires that at least one CE be the source of timing. Referring to Table 4, any of the 6 options listed can be used. The choice of which option to use will depend on economic and service needs. A PRS traceable source can be highly reliable and accurate but requires physical placement and substantial engineering support. It is for this reason that option 1 may be more expensive to administer than options 2 and 3.

Options 4 and 5 rely on the CE’s internal oscillator to provide a frequency source for the service clock. In this case, due to the relaxed need for additional timing equipment (BITS or SSUs) this option may be less expensive to administer than option 1 and require less engineering support.

Option 6 may yield undesirable slip performance due to the frequency difference between the free-running clocks. This option is generally the least expensive but also has the lowest overall performance.

7.3.4.1.2 Transport Timing – Single Service-Provider Network

Timing for the single service-provider network assumes that the service provider owns the TSP/IWF and all of the Ethernet devices in the MEN. The equipment will encompass synchronization domains: SD_{IWF} , SD_{TDM} , and SD_{ED} . For this case, it is up to the service provider to perform the synchronization administration of all transport and synchronization equipment.

Regardless of synchronization options that the service provider may use, as listed in Table 5, it is the ability of the service provider’s network to accurately transport the service clock that is most important. Therefore, the operation of the CES interworking function is key to transport timing.

For the CES interworking function (SD_{IWF}) must use timing that is consistent with the IWF type.

The TSP synchronization domain (SD_{TDM}) provides a foundation for the CE IWF. PRS traceable timing may be available via externally timing the TSP/IWF or line timing (from the MEN). It should be noted that the use of synchronization messaging (SSM) between the MEN and TSP/IWF is required to always ensure that the TSP/IWF is receiving PRS traceable timing. SSMs facilitate fault or protection switching from upstream failures. If SSMs are not available, then external timing is the preferred timing mode for PRS traceable timing.

7.3.4.2 Multi Service-Provider Owned Network

Synchronization administration for a multi service-provider owned network is illustrated in Figure 15.

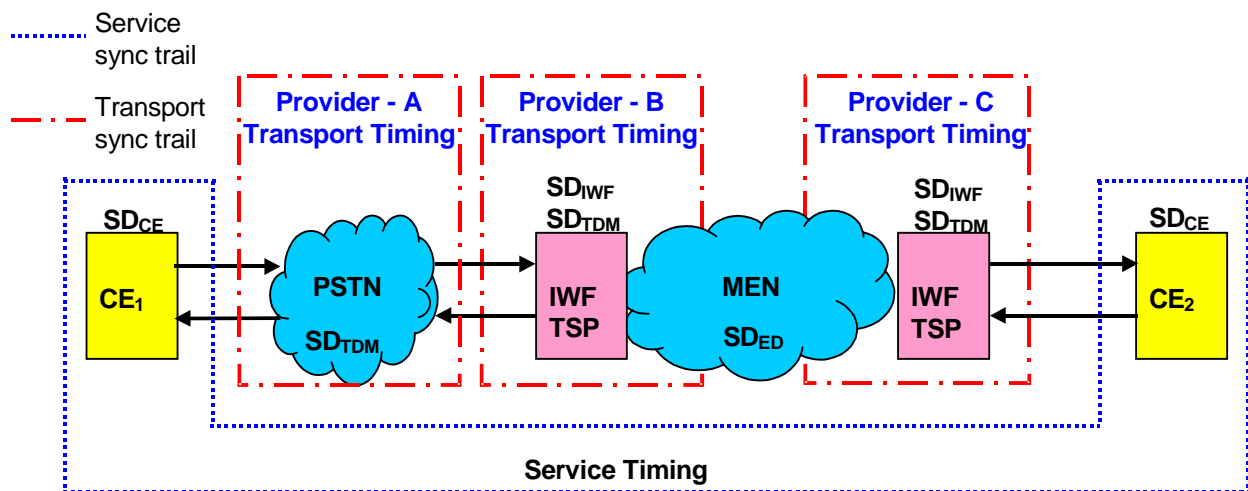

Figure 15: Synchronization Administration for a Multi Service-Provider Network

A summary of available timing options for a multi service-provider owned network is presented on Table 9.

Device	Timing Domain	Timing Options	Notes
CE	SD _{CE}	External	Customer Option: Requires a collocated BITS or SSU to supply a timing input to the CE. May be used as a source for the synchronization trail.
		Line	Customer Option: May be used at the end of a synchronization trail.
		Free-Run	Customer Option: May be used as the source for the synchronization trail.
PSTN	SD _{TDM}	External	Service Provider Option: Requires a collocated BITS or SSU to supply a timing input to the PE.
		Line – CE	Customer Option: May be used to recover timing from the received client signal. This mode should only be used if synchronization messaging is available (e.g. SONET or SDH line timing sources)..
		Line-TSP	Service Provider Option: Used only if the connecting TSP equipment is PRS traceable. This mode should only be used if synchronization messaging is available (e.g. SONET or SDH line timing sources)
		Free-Run	Service Provider Option: Used only if there is no suitable line or external timing source.
IWF	SD _{IWF}	See IA	Service Provider Option: Timing recovery for CES IWF must match the IWF type. Details can be found in the IA as specified on Table 2 (CES Interface Definition).
TSP	SD _{TDM}	External	Service Provider Option: Requires a collocated BITS or SSU to supply a timing input to the PE.
		Line – CE	Customer Option: May be used to recover timing from the received client signal. This mode should only be used if synchronization messaging is available (e.g. SONET or SDH line timing sources).
		Line – PSTN	Service Provider Option: Used only if the connecting PSTN equipment is PRS traceable. This mode should only be used if synchronization messaging is available (e.g. SONET or SDH line timing sources)
		Line-MEN	Service Provider Option: Used if the IWF can provide timing. Consistent with the service needs of the TSP. Options and capabilities for a specific IWF is specified per the appropriate IA.
		Free-Run	Service Provider Option: Used only if there is no suitable line or external timing source.
MEN	SD _{ED}	PRS Traceable	Service Provider Option: Requires that all elements use PRS traceable timing
		Non-PRS Traceable	Service Provider Option: Requires that one or more elements not use PRS traceable timing.

Table 9: Timing Options Multi-Service Provider Owned Network

Note that in the Multi-Service Provider configuration, the synchronization trails for service-timing and transport-timing are separate. Also notice that the transport timing can be TDM based (PSTN) or Ethernet based (MEN). Separation of these synchronization trails is typically done for administrative and liability reasons. An end customer will not be able to manage a service provider’s timing equipment. Likewise, a service provider would typically not use timing from a CE due to the reliability and liability issues associated with a single point of failure.

Separate synchronization trails also means that the physical timing source used to derive the service clock is not the same as that used in the transport network (TSP/IWF and MEN). This is not to say that the source for the service and transport cannot be PRS traceable, simply that one is not the source for the other.

7.3.4.2.1 Service Timing – Multi Service Provider Network

The Customer Edge synchronization domain (**SD_{CE}**) is owned and maintained by the customer. Timing for the CE (**SD_{CE}**) requires that at least one CE be the source of timing. Referring to Table 6, any of the 6 options listed can be used. The choice of which option to use will depend on economic and service needs. A PRS traceable source can be highly reliable and accurate but requires physical placement and substantial engineering support. It is for this reason that option 1 may be more expensive to administer than options 2 and 3.

Options 4 and 5 rely on the CE's internal oscillator to provide a frequency source for the service clock. In this case, due to the relaxed need for additional timing equipment (BITS or SSUs) this option may be less expensive to administer than option 1 and require less engineering support.

Option 6 may yield undesirable slip performance due to the frequency difference between the free-running clocks. This option is generally the least expensive but also has the lowest overall performance.

7.3.4.2.2 Transport Timing – Multi Service-Provider Network

Timing for the multi service-provider network assumes that no one service-provider owns the PSTN, TSP/IWF and all of the Ethernet devices in the MEN. The equipment will encompass synchronization domains: **SD_{IWF}**, **SD_{TDM}**, and **SD_{ED}**. For this case, it is up to each service provider to perform the synchronization administration of all transport and synchronization equipment in their domain.

Regardless of synchronization options that the service provider may use, as listed in Table 14, it is the ability of the service provider's network to accurately transport the service clock that is most important. Therefore, the operation of the CES interworking function is key to transport timing.

The PSTN synchronization domain (**SD_{TDM}**) preserves the service clock through the PSTN. PRS traceable timing may be provided to all of the PSTN's network elements (NEs) via externally by BITS or line timing from adjacent NEs. It should be noted that the use of synchronization messaging (SSM) between NEs may be required to ensure that each NE is receiving PRS traceable timing. SSMs facilitate fault or protection switching from upstream failures. If SSMs are not available, then external timing is the preferred timing mode for PRS traceable timing.

The TSP synchronization domain (**SD_{TDM}**) provides a foundation for the CE IWF. PRS traceable timing may be available via externally timing the TSP/IWF or line timing (from the MEN). It should be noted that the use of synchronization messaging (SSM) between the MEN and TSP/IWF is required to always ensure that the TSP/IWF is receiving PRS traceable timing. SSMs facilitate fault or protection switching from upstream failures. If SSMs are not available, then external timing is the preferred timing mode for PRS traceable timing.

For the CES interworking function (**SD_{IWF}**) must use timing that is consistent with the IWF type as specified in the appropriate IA.

7.3.4.3 Private (customer owned) Network

Synchronization administration for a private network is illustrated in Figure 16.

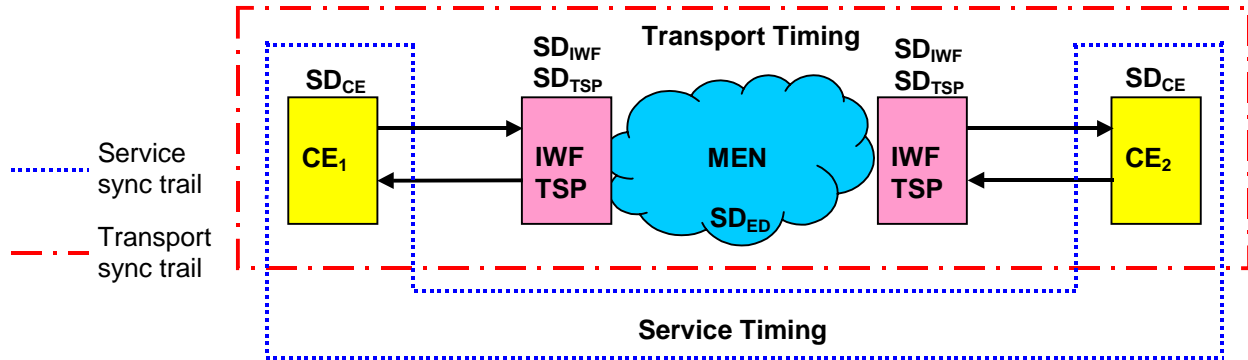

Figure 16: Synchronization Administration for a Private Network

A summary of available timing options for a private network is presented on Table 10.

Device	Timing Domain	Timing Options	Notes
CE	SD _{CE}	External	Customer Option: Requires a collocated BITS or SSU to supply a timing input to the CE. The most accurate means of timing distribution.
		Line	Customer Option: May be used at the end of a synchronization trail.
		Free-Run	Customer Option: May be used as the source for the synchronization trail.
IWF	SD _{IWF}	See IA	Service Provider Option: Timing recovery for CES IWF must match the IWF type. Details can be found in the IA as specified on Table 2 (CES Interface Definition).
TSP	SD _{TDM}	External	Service Provider Option: Requires a collocated BITS or SSU to supply a timing input to the TSP. The most accurate means of timing distribution.
		Line – CE	Customer Option: May be used to recover timing from the received client signal. This mode should only be used if synchronization messaging is available (e.g. SONET or SDH line timing sources).
		Line-MEN	Service Provider Option: Used if the IWF can provide timing. Consistent with the service needs of the TSP. Options and capabilities for a specific IWF is specified per the appropriate IA.
		Free-Run	Service Provider Option: Used only if there is no suitable line or external timing source.
MEN	SD _{ED}	PRS Traceable	Service Provider Option: Requires that all elements use PRS traceable timing
		Non-PRS Traceable	Service Provider Option: Requires that one or more elements not use PRS traceable timing.

Table 10: Timing Options for a Private Network

Note that in this configuration, the synchronization trails for service-timing and transport-timing overlap. This is allowed because the customer owns and operates the equipment that supports all of the synchronization domains. In this case, the customer and service provider are the same entity, so combining synchronization trails should not

create any problems. The rules for timing, as with the single and multi service-provider cases, should still be followed.

7.3.4.3.1 Service Timing – Private Network

The Customer Edge synchronization domain (SD_{CE}) is owned and maintained by the customer, just as the single service provider case. In fact, all timing aspects related to private networks are identical to those of the single service-provider case.

7.3.4.3.2 Transport Timing – Private Network

Timing for the private network assumes that the TSP/IWF and Ethernet devices in the MEN all owned by the same customer. This equipment encompass synchronization domains: SD_{IWF} , SD_{TDM} , and SD_{ED} . The options for configuring this equipment are shown in Table 10.

The timing options for the Private Network are the same as those of the single service-provider case with the exception of the line-CE mode for the TSP/IWF. In this mode, the TSP/IWF are allowed to use synchronization from client signal as sent by the CE. In order to ensure the best quality timing, it is recommended that the CE sourcing this client signal use PRS traceable timing. It should be noted that the use of synchronization messaging (SSM) between the CE and TSP/IWF are required to always ensure that they are receiving PRS traceable timing. SSMs facilitate fault or protection switching from upstream failures. If SSMs are not available, then external timing is the preferred timing mode for PRS traceable timing.

7.4 PERFORMANCE MONITORING AND ALARMS

The CES should allow the operation of the normal mechanisms for monitoring the performance of the TDM service, at the level of the TDM interface type. Generic performance monitoring requirements are specified in [G.826]. Performance monitoring in line with [G.826] is one-way, and occurs between two end-points. Specific requirements for particular services are documented in the Requirements section.

7.4.1 Facility Data Link

The Circuit Emulation Service will carry any signal that meets the bit rate requirement specified in Section 8. In the particular case of DS1 circuits using ESF framing, a Facility Data Link (FDL) may be present in the signal. The DS1 ESF Facility Data Link is used to carry once-per-second Performance Report Messages as described in [T1.403]. These messages carry information on numbers of CRCs, framing errors, line code violations and other impairments detected over the last second.

The CES IWF is allowed to monitor the FDL, and to modify the relative position of the FDL with respect to the TDM payload, but must not change messages carried by the FDL, or insert new FDL messages. For example, the Interworking Function may be required to monitor Performance Report Messages as described in [T1.403]. The means of carrying the FDL is to be defined in the Implementation Agreement.

7.4.2 Alarms

7.4.2.1 Unstructured Service

For unstructured services, all alarms received at the input of the Service Interface are carried through to the output Service Interface without modification, since they are embedded in the data on the wire. In addition to this, the IWF can detect a loss of signal (LOS) at the IWF Service Interface. Upon detection of LOS, the IWF is required to notify the IWF at the opposite end of the CES service.

7.4.2.2 Structured Service

For structured Nx64 service, the alarm status is not necessarily propagated within the data. Several kinds of alarms can be detected at the point where the Service Interface is received by the IWF. The definition of alarm states is given in [T1.403] for DS1 and [G.704] for E1. Some alarm situations require that an alarm condition detected at the point where the TDM Service Interface is received by the MEN-bound IWF be propagated downstream to the CE-bound IWF responsible for reproducing the bit stream.

7.4.2.3 Buffer Underflow and Overflow

The IWF at the egress of the MEN will require a buffer in which the re-assembled data stream is stored before it is transmitted out the Service Interface. The size of this buffer will be implementation dependent, but it must be large enough to accommodate expected MEN frame jitter, while small enough to not introduce excessive delay in the emulated circuit. This buffer will be subject to overflow or underflow if slight clocking differences exist between the upstream and downstream IWF, or in the presence of unexpectedly large network jitter. In the case of an underflow, or “data starvation” condition, data will have to be inserted into the TDM stream until a new Ethernet frame has arrived. The data to be inserted is implementation-dependent.

Under some circumstances, such as a failure in the MEN network carrying the emulated service, the flow of Ethernet frames to the re-assembly unit will stop for an extended period. This is effectively the same as a LOS condition on the TDM network. If this condition persists for a long period, this should be signaled to the downstream TDM equipment using a Trunk Conditioning procedure. For most applications, implementors are advised to use a 2.5 ± 0.5 s integration period, in a manner analogous to that used to integrate Loss of Signal to declare red alarm state.

Although not required as part of this specification, implementors may wish to consult Bellcore GR-1113-CORE and ETSI ETS 300 353 Annex D for advice on the handling of various fault conditions.

7.4.2.4 Alarms in CCS Signaling

This revision of this CES document does not provide any specific support for Common Channel Signaling (CCS) systems. CCS is supported in that it is transported transparently over the CES. However, this specification does not address a reaction of a CES IWF to an incoming AIS signal when CCS is used. It should be noted that the presence of the AIS signal will disrupt any CCS data link carried over that same link. This disruption will cause the signaling system that uses the CCS link to declare an alarm. In this case, no further conditioning is required.

Similarly, a second alarming condition (in CCS systems) is not addressed by this document. The situation is if the VC that carries the CCS link is different than the VC that carries the DS0s controlled by that CCS link. There is currently no means of conveying an alarm on that VC which carries the DS0s to the CCS system. This is similar to failure case in TDM networking where only some of the DS0s fail. In TDM networking, this case is sometimes handled by network management actions and other times by DS0 testing systems used just as calls are being established. But since this version of this document does not specify support for CCS signaling systems, this situation is left for further study.

7.4.3 End-to-End Delay

End-to-end delay requirements are application-specific. End-to-end delay requirements are therefore beyond the scope of this specification. However, it should be noted that excess delay could have adverse effects on some traffic types, such as voice.

7.5 SERVICE IMPAIRMENT

This section addresses impairments to the emulated TDM service caused by errors within the MEN. Principally it addresses the relationship between the performance parameters of the underlying Metro Ethernet Network (MEN) transport to the defined service impairment metrics for the TDM service being emulated – errored seconds (ES) and severely errored seconds (SES).

7.5.1 Errors within the MEN causing TDM service impairment

There are three performance parameters defined for an EVC that have an impact on the TDM service impairment metrics: Frame Loss, Frame Delay and Frame Jitter. In addition any bit errors induced in the data flow across the MEN will also have an impact on the TDM service, although there is no performance metric defined to measure this within the MEN.

7.5.1.1 Frame Loss

Frame loss is defined as the percentage of in-profile frames (“green” frames that are within CIR/CBS) not reliably delivered over a measurement interval T.

$$\text{Frame Loss}_T = (1 - \text{frames delivered to destination} / \text{total frames sent to destination}) \times 100$$

Frame loss will cause a burst of bit errors in the re-constructed TDM stream.

7.5.1.2 Frame Delay and Frame Jitter

Frame Delay is defined as the maximum delay measured for a percentile (P) of successfully delivered frames over a measurement interval T. Frame Jitter can then be derived from the Frame Delay measurement using the maximum and minimum of Frame Delay samples over same measurement interval T and percentile (P). Frame Jitter can be calculated as follows:

$$\text{Frame Jitter}_{T,P} = \text{Frame Delay}_{T,P}(\text{Max. measured delay value} - \text{Min. measured delay value})$$

Typically the Frame Jitter is used to size the re-assembly buffer in the IWF at the egress of the MEN (see section 7.4.2.3). This buffer is sometimes referred to as the “jitter buffer”. However, the Frame Jitter figure is calculated on a percentile of frame delay values, where the percentile is defined as part of the Service Level Specification. Therefore a small percentage of frames will arrive outside the specified jitter level. Depending on the size of the jitter buffer, these frames may either arrive too late to be played out, or too early to be accommodated within the buffer. Such frames will then be discarded, and must be considered lost for the purposes of reconstructing the TDM service.

7.5.1.3 Bit Errors

Bit errors induced in the MEN will normally be detected by a CRC error in the frame check sequence. Therefore, the errors will cause the whole frame to be discarded. On some occasions a frame containing bit errors may still yield a correct CRC value, but this is expected to be extremely rare. Therefore, as far as the IWF is concerned, any bit errors in the data stream will appear as lost frames.

7.5.1.4 Frame Error Ratio and IWF behaviour

The collective sum of all the above errors (frame loss, excess frame jitter and bit errors) can be aggregated into a single measure termed “Frame Error Ratio” (FER), defined as the total of all effects leading to the loss of or discarding of a frame. For the purposes of TDM emulation, an Ethernet frame is deemed to be errored if it:

- a. fails to arrive at the egress IWF
- b. arrives too late to be played out
- c. arrives too early to be accommodated in the jitter buffer
- d. arrives with bit errors causing the frame to be discarded

In order to maintain timing integrity, the IWF must then insert an equivalent number of octets of data into the reconstructed stream. The data to be inserted is application and/or implementation dependent. If the frame should subsequently arrive, it should be discarded.

7.5.2 Relationship to TDM service impairment metrics

For DS1, fractional DS1, and DS3 there are requirements in ANSI [T1.510] for SES and ES related to the access portion of a TDM link (which relates to the metro portion of the link). When voice was the predominant application, one could, assuming no error control, derive some reasonable requirements for BER since an end-to-end PCM-encoded voice signal would tolerate a 10^{-6} BER in the TDM circuit. (Source: SR-TSV-00275, Iss. 1, March 1991). Although it should be noted that with Extended Super Frame (ESF) a loss of a single bit within a frame will cause a block error to be detected by the error detection code resulting in a ES even if the voice quality was not adversely effected. The following discussion of ES and SES assumes an absence of error control in the MEN.

For the European standards, there are equivalent metrics defined in [G.826]. The Errored Second Ratio (ESR) and Severely Errored Second Ratio (SESR) are defined across an international link rather than a metro, with guidelines for calculating the requirement on the national portion of the link. [G.826] does not break down the figures further to give the requirement on the metropolitan portion. In the discussion below, the national figures are used to define an upper bound on the MEN performance requirement.

7.5.3 Errored Seconds Requirement for PDH Circuits

An ES is a one-second interval with one or more bit errors. Each 1.544 Mbits/s (including Nx64kbits/s) and 44.736 Mbits/s channel requires that, over 30 or more consecutive days, fewer than 0.25% and 0.125%, respectively, of the seconds are errored seconds (Source: [T1.510]). The conversion of ES for PDH circuits to bit error ratio (BER) and frame error ratio (FER) for Ethernet CES virtual circuits is dependant on factors such as the number of TDM frames packed into the CES Ethernet frame (packing density) and the size of the CES header attached to each Ethernet CES frame.

Conversion of the Errored Seconds requirements to an Ethernet Frame Error Ratio is possible based on knowledge of the number of TDM frames packed into each Ethernet frame containing CES. Figure 17 shows the allowed Frame Error Ratio (FER) for given packing densities. This FER is for the Ethernet Virtual Circuit (EVC) associated with the circuit emulated service, assuming that only the associated CES frames are used in the frame loss calculation. Values of FER for specific packing densities (8 T1 or E1 frames and 2 T3 or E3 frames) are given in Table 11.

The FER is derived from the Errored Seconds objective by the following equation:

$$FER = \%ES / (100 * CES \text{ frame rate}) \dots\dots\dots [1]$$

Where: CES frame rate = TDM data rate / (N * bits per TDM frame)
 N = number of TDM frames per CES frame
 Bits per TDM Frame = 193 for 1.544 Mbits/s; 4760 for 44.736 Mbits/s

This figure has to include all possible sources of lost or errored Ethernet frames, as described in section 7.5.1. It does not allow breakdown into individual causes of error.

	1.544 Mbits/s (T1)	1.544 Mbits/s (T1 enhanced)	44.736 Mbits/s (T3)	2.048 Mbit/s (E1)	34.368 Mbit/s (E3)
%ES (note 1, 2)	0.25	0.0625	0.125	0.7	1.3125
FER (note 3, 4)	2.5×10^{-6}	6.3×10^{-7}	2.7×10^{-7}	7.0×10^{-6}	3.3×10^{-6}

Table 11: Example conversion from ES to FER for Ethernet Virtual Circuit

- Note 1 T1, T2 enhanced and T2, reference [T1.101] (Access segment of the reference model)
- Note 2 E1, E3 reference [G.826], using 17.5% of the international objective as defined in section 7.2. This represents the national objective for errored seconds, and hence is higher than would be allocated to the access segment, but provides an upper bound.
- Note 3 See Figure 17 for details of FER curves vs packing density

Note 4 FER values represent the packetization of 8 T1 or E1 frames and 2 T3 or E3 frames in an Ethernet frame

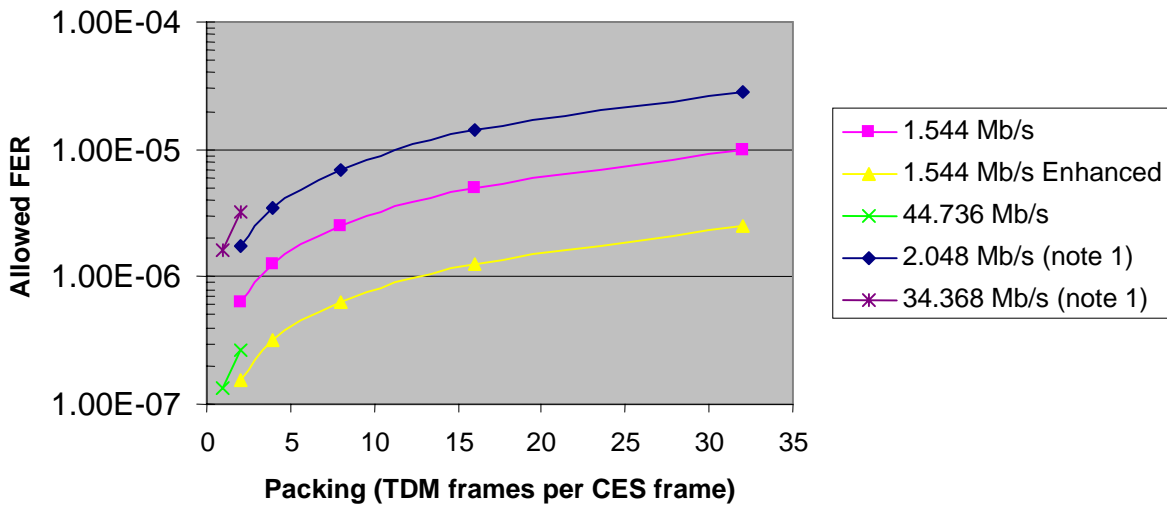

Figure 17: Allowed Frame Error Ratio to meet ES objectives

Note 1 As with the table above, E1 and E3 figures use the national objective for ES. This is higher than would be expected for a metro network, and hence lower frame error ratio is required in a real MEN. The exact value is for further study.

7.5.4 Severely Errored Seconds Requirement for PDH Circuits

A severely errored second (SES) is defined as a period of time, during which bits are transferred from a source to a destination, where > 30% of the blocks received are errored, or at least one severely disturbed period occurred. A severely disturbed period occurs when, over a period of time equivalent to four contiguous blocks or 1 ms, which ever is larger, all contiguous blocks are affected by a high bit error density of >10⁻². This definition applies for a specified block size.

Note: Where a suitable block is not available, an alternate definition can be used: - A specified period of time during which bits are transferred from a source to a destination, where a BER worse than 10⁻³ occurs [T1.503].

The relationship between block size and CES frame size will greatly influence the allowed FER. The block size related to an Extended Super Frame (ESF) is 193 bits x 24 whereas a DS3 block is 4760 bits. For ESF a number of CES Frames may be required to form a block and any loss of a CES frame will impact the whole block. For DS3 a single CES frame can carry multiple blocks and the loss of a CES Frame will impact all of the blocks in the CES Frame. Figure 18 shows the relationship between packing and allowed FER to meet the SES requirement of <30% of the blocks received being errored for a SES requirement of 0.01%. It should be noted that for DS3 services only 2 DS3 frames can be packed in a CES Ethernet frame. The requirement for SES is 0.01% for the Access portion as defined in [T1.510] for all PDH services (1.544 Mbits/s, 1.544 Mbits/s enhanced and 44.736 Mbits/s).

In the case where errors are Poisson in nature and not correlated then equations 2 through 4 can be used to calculate FER for SES. Results are plotted in Figure 18.

If $F_s/N - \text{Int}(F_s/N) = 0$ then

$$\text{FER} = \frac{\% \text{SES} * \text{BE} * N}{F_s} \dots \dots \dots [2]$$

Where: N = number of TDM frames per Ethernet CES frame

Fs = number of TDM frames in a block (e.g. 24 for ESF)
 FER = FER limit for %SES
 %SES = percent severe error second limit = 0.01%
 BE = the block error limit = 30%

If $Fs/N - \text{Int}(Fs/N) < 0$ then

$$FER = \frac{\%SES * BE}{(Fs/N+1 - \text{GCD}(Fs,N) / N)} \dots\dots\dots [3]$$

Where: N = number of TDM frames per Ethernet CES frame
 Fs = number of TDM frames in a block (e.g. 24 for ESF)
 FER = FER limit for %SES
 %SES = percent severely errored seconds limit = 0.01%
 BE = the block error limit = 30%
 GCD = Greatest Common Divisor function

If there are one or more blocks packed in an Ethernet CES Frame and the blocks do not span Ethernet CES Frame boundaries then:

$$FER = \%SES * BE \dots\dots\dots [4]$$

Where: FER = FER limit for 0.01% SES
 %SES = percent severely errored seconds limit = 0.01%
 BE = the block error limit = 30%

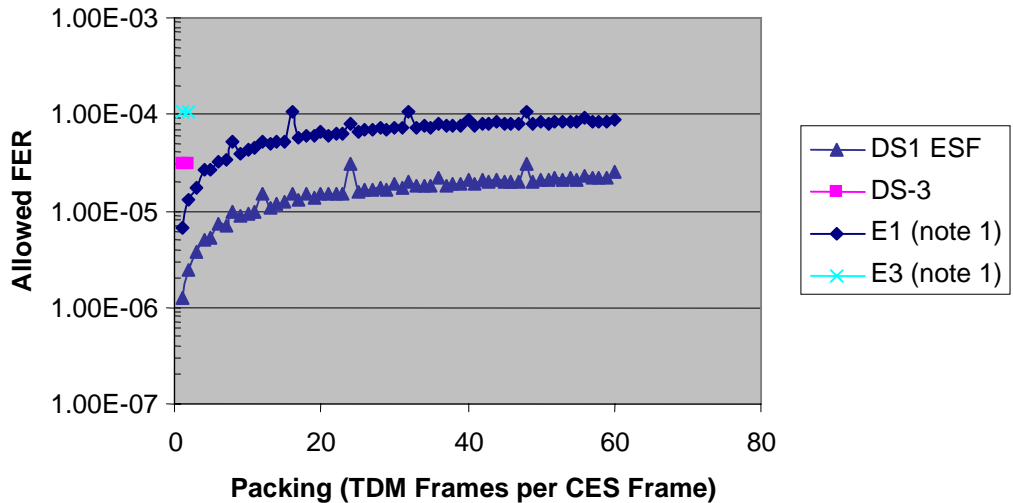

Figure 18: Relationship between Packing and FER for 0.01% SES

Note 1 As with the ES figures, E1 and E3 figures use the national objective for SES. This is higher than would be expected for a metro network, and hence lower frame error ration is required in a real MEN. The exact value is for further study.

Note 2 The discontinuities in the plots are due to the boundaries where a block does not span across an Ethernet CES frame.

In the case where no block definition is available then the SES definition given in ANSI T1.510-1999 can be used. The resultant FER limits are as follows: 10^{-3} BER on the TDM data stream is equivalent to a TDM frame loss ratio of 19% for T1. The resultant FER is given by:

$$FER = \%SES * 0.19/N \dots\dots\dots [5]$$

Where: N = number of TDM frames per Ethernet CES frame
 FER = FER limit for 0.01% SES
 %SES = percent severely errored seconds limit = 0.01%

The resultant FER is given in Figure 19.

It is recommended that where a block is clearly defined, such as for ESF or DS3, that the requirements given Figure 18 are used, and where no block requirement is given that Figure 19 be used. It should be noted that a 10^{-3} BER on a TDM data link carrying ESFs would result in 100% of the blocks being errored.

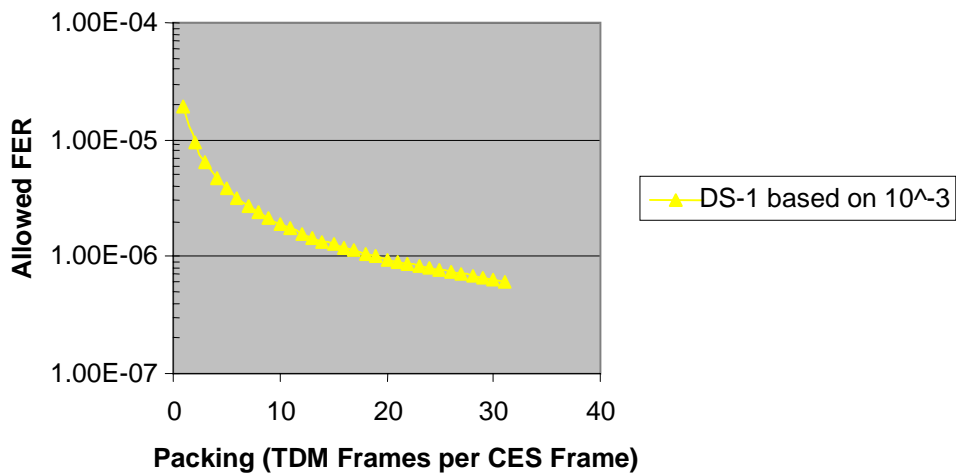

Figure 19: Relationship between Packing and FER for 0.01% SES based on 10^{-3} BER on end to end TDM data stream

7.5.5 Service Impairments for SONET/SDH Circuits

This section provides an analysis of the Frame Error Ratio (FER) requirements from the Metro Ethernet Network (MEN) in order to support SDH/SONET Circuit Emulation Services (CES).

7.5.5.1 Performance Objectives for the SONET/SDH network

The error performance limits used in this document are taken from ITU recommendations [M2101.1] and [G.826].

[M2101.1] describes a Hypothetical Reference Model (HRM) for performance of the international path. The allocation of the performance objectives per segment of the path in percentage of the end to end allocation is provided in Table 2A of [M2101.1]. For the purpose of calculation of performance objectives for the Metro connections, 2% of the end to end allocation is taken, which correspond to a segment with diameter less than 500 km.

7.5.5.1.1 ES/SES evaluation criteria

[M2101.1] gives the guidelines for ES/SES evaluation criteria for LOVC in Table B.1 and for HOVC in table B.2. From the guidelines specified in these tables, the interpretation of ES and SES for packet loss and BER effects in SDH/SONET CES can be derived, and are discussed in the next section.

7.5.5.1.2 Performance Objectives in [G.826]

Performance objectives as defined in [G.826] are measured in ESR, SESR and BBER. The definitions of these three terms are:

ESR: Error Second Ratio; The ratio of Error Second (ES) to total seconds during a fixed measurement interval.

SESR: Severe Error Second Ratio: The ratio of SES to total seconds in available time during a fixed measurement interval.

BBER: Background Block Error Ratio: The ratio of Background Block Errors (BBE) to total blocks in available time during a fixed measurement interval. The count of total blocks excludes all blocks during SESs.

Block sizes used for SDH path performance monitoring is provided in Table C.1 of [G.826].

The End to End error performance objectives for international digital Hypothetical Reference Model at or above the primary rate is given in Table 1 of [G.826].

The recommended time period for evaluation of the performance objectives is one month.

7.5.5.2 MEN Performance Objectives

This section discusses the interpretation of the requirement specified in the previous section to the Metro Ethernet Networks. The requirements from the MEN are specified in maximum Frame Error Ratio (FER) provided by the MEN for the various SDH/SONET services and rates.

The SDH/SONET service provided over the MEN should stand within the limits of the ESR, SESR and BBER requirements specified in [G.826] and the ES and SES requirements specified in [M2101.1]. These requirements can be directly tested for each emulated circuit using standard SDH/SONET and PDH testers.

The [G.826] requirements are specified in ESR, SESR and BBER. The MEN requirements are specified in BER and FER. The derivation requires assumptions on the distribution of BER and FER within the MEN.

1. ESR requirements derive FER MEN requirements assuming that the errors does not occur in bursts, rather each error occur in a different measurement interval (separated by at least one second). Since errors can occur in bursts, the actual FER measured in MEN may be higher than the requirements derived from ESR and still meet [G.826] requirements.
2. BBER measures the rate of blocks received in error, without counting the blocks received in SES intervals. Since the number of blocks per packet is known, MEN FER requirements can be directly deduced. The FER requirements calculated from ESR is usually stricter than the requirements calculated from BBER. Therefore FER measured in the MEN may be higher than the FER requirement derived from BBER, and still meet [G.826] requirements, as some of the errors would account for SES.
3. SESR requirements do not directly derive FER requirements. SESR requirement limits the number and length of bursts of errors. Rather, the maximal FER that can be accounted to SES is calculated.

7.5.5.2.1 Error Second Objective

Table 12 summarizes the FER objectives for MEN derived from ESR requirements defined in [G.826]. Note that these requirements correspond to FER assuming that only one error occurs each second. Performance objectives for burst of errors or multiple packet drops are covered in BBER objective section.

Path	Packing pkt/blks	Block Size bits	Rate pps	P Size bits	ESR G.826	ESR G.826 MEN	CES FER
VC-11	1	832	2000	1056	0.04	8.00E-04	4.00E-07
	4	832	8000	516	0.04	8.00E-04	1.00E-07
VC-12	1	1120	2000	1344	0.04	8.00E-04	4.00E-07
	4	1120	8000	516	0.04	8.00E-04	1.00E-07
VC-3	1	6120	8000	6344	0.05	1.00E-03	1.25E-07
	3	6120	24000	2264	0.05	1.00E-03	4.17E-08
VC-4	3	18792	24000	6488	0.16	3.20E-03	1.33E-07
	1.8	18792	14400	10664	0.16	3.20E-03	2.22E-07
VC-4-4c	9	75168	72000	8576	0.16	3.20E-03	4.44E-08

Table 12: Sparse FER objectives for MEN [G.826]

Where:

Path: The SDH/SONET LOVC or HOVC service.

Packing: Defines the number of packets carrying a single block. Packing values in orange represent the default packing values for SDH/SONET emulation.

Block Size: Block sizes in bits as defined in [G.826]

Rate: Rate of the channel in packets per second

P Size: The Ethernet frame size in bits. The overhead used for calculation of the CES BER ration comprise of 14 Ethernet header bytes, 4 VLAN tag bytes, 4 bytes for circuit multiplexing label 4 bytes for CES control word and 4 bytes for Ethernet CRC, altogether 28 bytes. Where applicable (VC-11 and VC-12 8k flows), padding to minimal Ethernet is added as well.

ESR [G.826]: The end to end performance objective for international link

ESR MEN: 2% of [G.826] specified end to end performance objective, suitable for the MEN segment.

CES FER: The maximal Frame Error Ratio within the CES Ethernet frames. This is derived from the following equation:

$$CES FER = ESR MEN / Rate$$

7.5.5.2.2 BBER Objectives

Assuming that no Severe Error Seconds occur in a measurement interval, the BBER ratio provide a direct upper limit for Frame Error Ratio, as the relation between blocks and packets is fixed given by the packing ratio.

Burst of errors may cause severe error seconds. When a severe error second occur, the frames within this second (both good and errored) are not counted in these requirements.

Path	Packing pkt/blks	Block Size bits	Rate pps	P Size bits	BBER G.826	BBER G.826 MEN	CES BFER
VC-11	1	832	2000	1056	0.0002	4.00E-06	2.00E-06
	4	832	8000	516	0.0002	4.00E-06	2.00E-06
VC-12	1	1120	2000	1344	0.0002	4.00E-06	2.00E-06
	4	1120	8000	516	0.0002	4.00E-06	2.00E-06
VC-3	1	6120	8000	6344	0.0002	4.00E-06	2.00E-06
	3	6120	24000	2264	0.0002	4.00E-06	2.00E-06
VC-4	3	18792	24000	6488	0.0002	4.00E-06	2.00E-06
	1.8	18792	14400	10664	0.0002	4.00E-06	2.00E-06
VC-4-4c	9	75168	72000	8576	0.0001	2.00E-06	1.00E-06

Table 13: Background FER and BER objectives for MEN [G.826]

Where:

- Path: The SDH/SONET LOVC or HOVC service.
- Packing: Defines the number of packets carrying a single block. Packing values in orange represent the default packing values for SDH/SONET emulation.
- Block Size: Block sizes in bits as defined in [G.826]
- Rate: Rate of the channel in packets per second
- P Size: The Ethernet frame size in bits. The overhead used for calculation of the CES BER ration comprise of 14 Ethernet header bytes, 4 VLAN tag bytes, 4 bytes for circuit multiplexing label 4 bytes for CES control word and 4 bytes for Ethernet CRC, altogether 28 bytes. Where applicable (VC-11 and VC-12 8k flows), padding to minimal Ethernet is added as well.
- BBER: Background Block Error Ratio (BBER) objectives as defined in [G.826]
- BBER MEN: BBER objectives for MEN, 2% of BBER end to end requirement
- CES BFER: The maximal background FER for the CES frames. BFER accounts for both single as well as small bursts of frame errors. CES BFER does not count frames in Severe Error Seconds, e.g. during large bursts of FER. This is derived from the following equation:

$$\text{CES BFER} = \text{BBER MEN} / 2$$

A packet does not carry more than one block. A packet may carry segments from two blocks. To account for the latter, the 2 factor is added.

7.5.5.2.3 Severe Error Second Objectives

The criteria for SES are defined in table B1 and B2 of [M2101.1]. In particular, one of the SES criterions is errors in over 300 blocks during one second. In SDH/SONET emulation this corresponds to an error or loss of about 300 frames during one second interval. We refer to these cases as connectivity problems within the MEN. MEN connectivity problems may be failure of a switch or a link that leads to losing a series of packets.

CES service running over MEN with Frame Error Ratio specified in Table 14 can still stand within [G.826] requirements, if most errors occur within single intervals, i.e. within the SES intervals.

Path	Packing pkt/blks	Block Size bits	Rate pps	P Size bits	SESR G.826	SESR G.826 MEN	CES SESFER
VC-11	1	832	2000	1056	0.002	4.00E-05	4.00E-05
	4	832	8000	516	0.002	4.00E-05	4.00E-05
VC-12	1	1120	2000	1344	0.002	4.00E-05	4.00E-05
	4	1120	8000	516	0.002	4.00E-05	4.00E-05
VC-3	1	6120	8000	6344	0.002	4.00E-05	4.00E-05
	3	6120	24000	2264	0.002	4.00E-05	4.00E-05
VC-4	3	18792	24000	6488	0.002	4.00E-05	4.00E-05
	1.8	18792	14400	10664	0.002	4.00E-05	4.00E-05
VC-4-4c	9	75168	72000	8576	0.002	4.00E-05	4.00E-05

Table 14: Maximal FER accounted by SESR [G.826]

Where:

- Path: The SDH/SONET LOVC or HOVC service.
- Packing: Defines the number of packets carrying a single block. Packing values in orange represent the default packing values for SDH/SONET emulation.
- Block Size: Block sizes in bits as defined in [G.826]
- Rate: Rate of the channel in packets per second

P Size: The Ethernet frame size in bits. The overhead used for calculation of the CES BER ration comprise of 14 Ethernet header bytes, 4 VLAN tag bytes, 4 bytes for circuit multiplexing label 4 bytes for CES control word and 4 bytes for Ethernet CRC, altogether 28 bytes. Where applicable (VC-11 and VC-12 8k flows), padding to minimal Ethernet is added as well.

CES SESFER The maximal Frame Error Ratio within the CES Ethernet frames that can be accounted for SES. This is derived from the following equation:

$$CES\ SESFER = SESR\ MEN$$

7.5.5.3 Summary & Discussion

Table 15 describes the FER MEN requirements. The actual FER can range between CES FER and CES SESFER and [G.826] Requirements would still be met.

Path	Rate pps	CES FER	CES BFER	CES SESFER
VC-11	2000	4.00E-07	2.00E-06	4.00E-05
	8000	1.00E-07	2.00E-06	4.00E-05
VC-12	2000	4.00E-07	2.00E-06	4.00E-05
	8000	1.00E-07	2.00E-06	4.00E-05
VC-3	8000	1.25E-07	2.00E-06	4.00E-05
	24000	4.17E-08	2.00E-06	4.00E-05
VC-4	24000	1.33E-07	2.00E-06	4.00E-05
	14400	2.22E-07	2.00E-06	4.00E-05
VC-4-4c	72000	4.44E-08	1.00E-06	4.00E-05

Table 15: MEN FER Requirements for SDH/SONET CES

MEN that can not stand within the FER requirements can still run SDH/SONET Circuit Emulation Services. The implication would be that larger than 2% of the international end to end ESR, BBER and SESR requirements would be used by the MEN. A similar approach is taken for other technologies in [M2101.1] (Satellite links).

7.5.6 Availability Requirements

Network unavailability is specified in [T1.510] for DS1 and DS3, [T1.514] for SONET, and in [G.827] for E1, E3 and SDH circuits. The “unavailable state” is entered at the start of a period of 10 consecutive Severely Errored Seconds (SES). The “available state” is resumed at the start of a period of 10 consecutive seconds of which none are severely errored.

Translating this to give an understanding of the availability of an EVC used to carry an emulated circuit requires knowledge of the level of errors in a given second that will result in a SES. One difficulty is that there are several ways of defining a SES.

[T1.503] gives the following three definitions of SES:

- Either >= 30% of blocks received are errored*definition 1*
- Or BER > 10⁻² for four consecutive blocks*definition 2*
- Or BER > 10⁻³ (where no suitable blocks are defined)*definition 3*

[G.826] gives two definitions of a SES:

- Either >= 30% of blocks received are errored*same as definition 1*
- Or one or more defects (i.e. LOS, AIS, LOF)*definition 4*

Taking the first definition, if all the errored CESoETH frames are consecutive, then this translates into a simple level of 30% or errored CESoETH frames per second. If the errors are randomly or evenly distributed, then the level of

errors will depend on the number of blocks contained in each CESoETH frame, and the exact distribution of the errors (e.g. has the error hit a new block, or hit an already errored block?).

However, the other definitions place much stricter requirements on the FER. Definition 2 requires only 4 errored CESoETH frames to yield a SES (assuming each packet hits a different block). However, with the assumption that errored frames are consecutive, an FER of around 1% would be required to yield a SES.

Definition 3 translates simply into an FER of $>0.1\%$ to yield a SES (i.e. > 1 errored CESoETH frame in 1000).

Definition 4 is the strictest, since it requires only one errored CESoETH frame to yield an SES (since each lost frame may result in a temporary defect, e.g. AIS). However, given a CESoETH frame rate in the region of 1000 frames per second, it is similar to definition 3.

Therefore in the worst case, one errored CESoETH frame per second for 10 consecutive seconds may cause unavailability of the TDM service. With the use of suitable frame error concealment techniques in the CES IWF, (e.g. to prevent loss of multiframe synchronization), loss of availability of the TDM service may be reduced.

7.6 TDM SIGNALING

It is not normally required for Circuit Emulation Service to intercept or process TDM signaling, e.g. Channel Associated Signaling (CAS) or Common Channel Signaling (CCS). Signaling is embedded in the TDM data stream, and hence it is carried end-to-end across the emulated circuit. The signaling can be extracted by the end equipment from the data that has been transported across the MEN.

The exception is Nx64 kbit/s service where CAS signaling is supported. Nx64 kbit/s Service with CAS requires direct recognition and manipulation of the signaling bits by the CES IWF. This mode is necessary to support multiplexed Nx64 kbit/s applications requiring DS1 Robbed Bit Signaling or E1 CAS support, where the association between the signaling bits and the channel may otherwise be lost.

7.7 LOOPBACKS

Loopbacks should be supported at the level of the TDM interface type. Loopback of internal multiplexed levels (e.g., a DS1 level inside an OC-3 line) is outside the scope of this document.

7.7.1 Provider Controlled Loopbacks

It is suggested that provider-controlled loopbacks should be supported in the manner illustrated in Figure 20, where the direction of loopbacks is from PE1 (near end) towards PE2 (remote end). Loopback for PE2 to PE1 is the reverse of Figure 20. The aim of the loopback is to isolate the fault with respect to PE1. Therefore, four loopbacks at the system level are suggested:

- 1) a PE1-CE1 facility loopback, which should be located at a point within the provider's network as close as practicable to the Network Demarcation, for example, at a final span line repeater or SmartJack;
- 2) a PE1 terminal loopback of the TDM interface;
- 3) a PE1 terminal loopback of the MEN interface; and
- 4) a PE1-PE2 MEN loopback.

The loopback at the Network Demarcation must comply with the appropriate specification for the TDM interface type (e.g. ANSI [T1.403] for a DS1 interface). Refer to [T1.107] for more information on how to handle loopbacks.

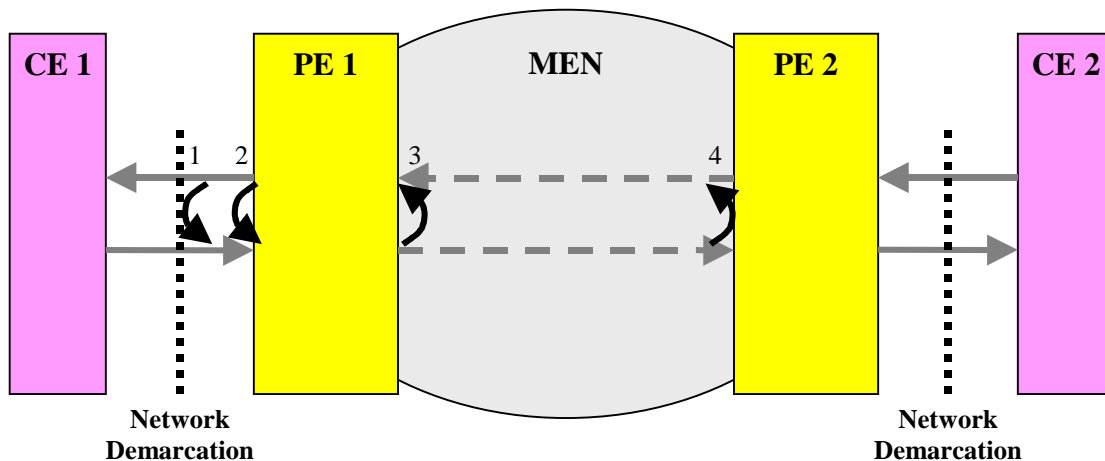

Figure 20: Provider Controlled Loopback Points

7.7.2 Customer Controlled Loopbacks

It is also possible for customers to use loopbacks to verify the operation of either their own equipment, or of the service being provided. The aim of the loopback is to isolate the fault with respect to a particular item of customer equipment (e.g. CE1), while treating the service provider network as a “black box”. Therefore, two loopbacks are suggested, as illustrated in Figure 21:

- 1) Local loopback at CE1
- 2) Remote loopback at CE2

The required loopbacks for CE2 are the reverse of Figure 21.

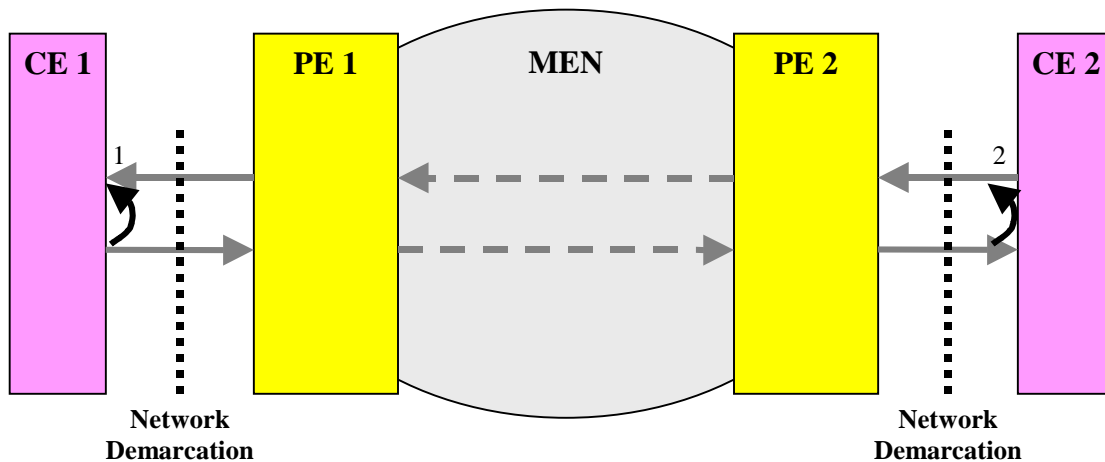

Figure 21: Customer Controlled Loopback Points

Customer controlled loopbacks are often initiated under manual control, although signaling may be provided to operate the remote loopback. The nature of such signaling is implementation specific. Customers are not normally able to control the provider loopbacks shown in Figure 20, except via a service call to the provider concerned.

7.8 PROTECTION

TDM networks usually include protection mechanisms for service recovery in less than 50ms. The CES solution should fit into such a protection scheme. This means the following:

- A CES service running over a MEN should have capabilities for sub-50ms protection within the MEN part.
- A failure of the TDM interface connecting a TDM legacy network to the MEN should cause a switchover to an alternative TDM interface. This switch should interact both with the MEN and with the legacy network, so that both sides of the interface start working with the alternative interface.

The following scenarios may be relevant for CES protection:

7.8.1 Scenario 1 – dual unprotected services

In such topologies a failure of one of the interfaces connecting between the TDM and MEN, or inside the MEN will cause the TDM network to work with the alternative CES connection. This may use 1+1 protection, 1:1 protection or 1:N protection, but is outside the scope of the CES solution.

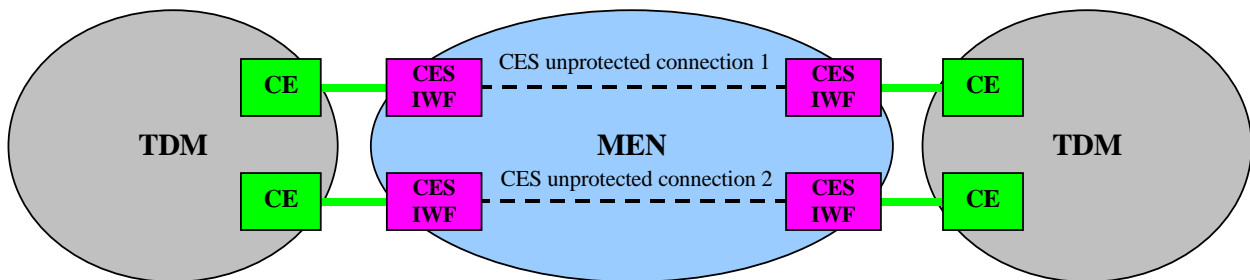

Figure 22: Dual unprotected services

The CES service is a non-protected service. Protection is established through the mechanisms of the TDM network connected on both sides of the MEN. For example, a SONET network connected on both sides of the CES connection could perform the protection switching based on either APS (Automatic Protection Switching) or BLSR (Bi-directional Line Switched Ring). Since the protection related information is carried in the line overhead (LOH), there are two possibilities:

- The CES service is not terminating the line layer. The protection information is carried across the MEN to the other side.
- The CES service is terminating the line layer. Upon failure of the path in the MEN, the PE updates the relevant protection bytes in the LOH within the requirements of SONET/SDH, so that the SONET/SDH equipment can make the switching in time. This may be by asserting AIS/RDI bits for the line.

7.8.2 Scenario 2 – dual protected services

This scenario is similar to the previous one; however, each CES connection is protected inside the MEN.

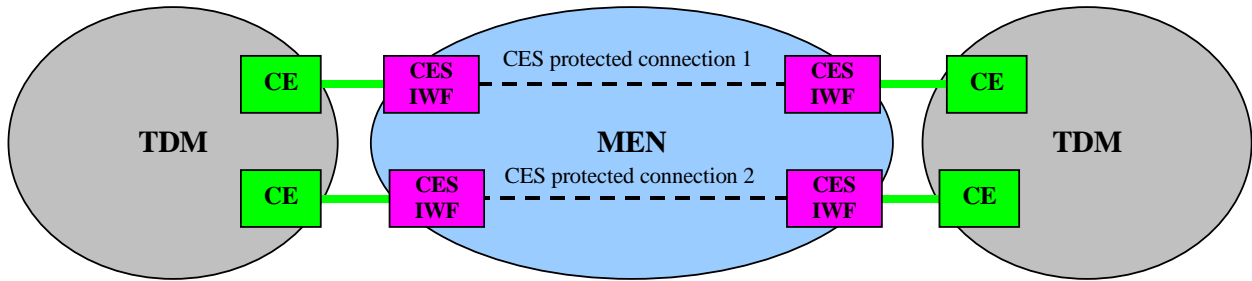

Figure 23: Dual protected services

In case of a failure in the TDM interface, the behavior is similar to the previous scenario.

In case of a failure inside the MEN, both the MEN internal mechanisms may trigger bypass, and the TDM network may initiate a switch to the alternate TDM interfaces as well. This requires careful design in order to avoid races between the TDM and the MEN protection mechanisms.

7.8.3 Scenario 3 – Single protected service

In this scenario, a single TDM interface is used on each side of the MEN. In this case, the CES connection in the MEN needs to be protected using MEN protection mechanisms. A failure inside the MEN would be bypassed in less than 50ms, so that service is maintained.

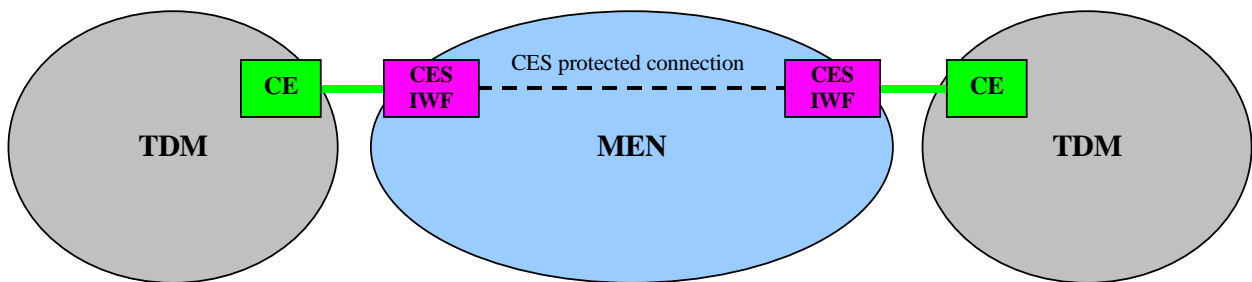

Figure 24: Single protected service

This scenario does not cover a case of TDM interface failure. The end-to-end protection mechanisms require detecting the liveliness of an end-to-end path. This is done generically through an OAM mechanism. Note that in the case of CES, traffic is constantly flowing through the active path (unlike Ethernet connections where there may be silent periods on the connection). Receiving traffic at the end of the path can therefore be used for detecting of the path liveliness, and trigger switch-over in case of failure.

7.8.4 Scenario 4 – Single to dual interface service

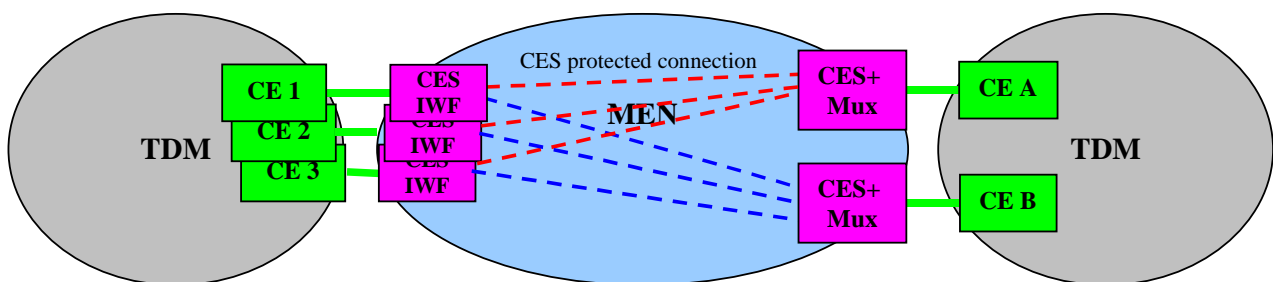

Figure 25: Single to dual interface connection

In this topology, there is a single TDM interface on one side of the MEN and two on the other side. This scenario is typical of a network where the right side is a server/hub. For example, multiple users connected with DS1 lines to a central office with OC-3. The subscribers may get a single DS1 interface, while on the other side there are 2 OC-3 uplinks, so that a failure of the OC-3 uplink (or even the TDM equipment attached to it) will still enable using the other OC-3 link.

In this case traffic coming in from CE1, CE2, CE3 is sent on both internal connections to CE A and CE B. It is multiplexed into a single higher rate TDM link going towards CE A & CE B.

On the other direction, traffic coming from CE A & CE B is de-multiplexed, and each lower rate is sent towards its destination CE (1/2/3).

The links between the end-subscribers in CE1/2/3 and the MEN are not protected. However, each such link affects only one subscriber. On the central office side, each link affects multiple subscribers, and is therefore protected.

Each CES on the left side can select the source for (red or blue) of the lower rate it sends towards CE1/2/3.

In the other direction, each CES connected to CE1/2/3 sends two copies of the traffic, one towards CE A, and one towards CE B. Both CE A and CE B receive traffic on their TDM links, and can select between them.

7.9 SERVICE QUALITY

In general, CES should aim to perfectly emulate the TDM services, thus allowing service providers a migration path to MENs, whilst not sacrificing service quality. Non-compliance of an emulated service to the TDM service requirements as specified in the relevant ANSI and ITU documents shall be explicitly stated in the implementation agreement, as well as the conditions under which this non-compliance occurs.

7.10 EFFICIENCY

The CES solution should try to minimize both network delay and network bandwidth needed for transporting the TDM traffic. During setup of an emulated circuit, the CES solution should enable the MEN provider to favor efficiency over network delay and vice-versa, by being able to define the size of TDM payload transmitted in each Ethernet frame.

For example, a small payload results in low latency, since the CES IWF does not have to wait long for the Ethernet frame to fill. However, the ratio of header to payload is large, making small Ethernet frames inefficient in terms of bandwidth consumption in the MEN. Therefore, the payload should be made as large as possible, while still keeping within the latency budget for the emulated circuit.

It is not required to be able to dynamically adjust the size of the payload while an emulated circuit is in operation.

7.11 NON-REQUIREMENTS

The MEN need not provide any functionality above and beyond that already present in today's SONET/SDH, or PSTN networks; i.e. the MEN should not try to provide a "better" TDM service than today's networks.

8. Circuit Emulation Service Requirements

This section provides the detailed, formal requirements for the services defined in Section 6.

8.1 STRUCTURED DS1/E1 Nx64 KBIT/S SERVICE

A number of applications currently use Nx64 kbit/s services. For example, there are a number of DTE interfaces and video codecs that are capable of operating at Nx64 kbit/s rates for $N > 1$.

Nx64 Service is intended to emulate a point-to-point Fractional DS1 or E1 circuit. The service is typically accessed via either 1.544 Mbit/s DSX-1 [T1.102] interfaces or a 2.048 Mbit/s E1 [G.703] interfaces. For DS1, N of the 24 timeslots available at the DSX-1 interface, where $1 < N \leq 24$, are carried across the MEN and reproduced at the output edge. For E1, $1 < N \leq 31$. These services will be either with or without support for channel associated signaling (CAS). Nx64 Services without CAS support will be referred to as "Basic Service".

8.1.1 TDM Framing

- R1. DS1 Nx64 Service SHALL be capable of interfacing with circuits using Extended Superframe Format.
- R2. DS1 Nx64 Service MAY provide SF framing at a DS1 Service Interface.
- R3. E1 Nx64 Service SHALL be capable of interfacing with circuits using [G.704] framing.

8.1.2 Timeslot Assignment

- R4. The Nx64 Service SHALL carry any group of N 64 kbit/s timeslots, where N can be 1 to 24 or 1 to 31 for DS1 and E1 respectively.
 - a. The timeslots assigned to a virtual channel are not required to be contiguous.
 - b. Assignment of timeslots is not required to be the same on the input and output ends of the virtual channel.
- R5. The CES IWFs MUST deliver octets at the output in the same temporal order as they were received at the input.
- R6. The Nx64 service MUST maintain 125µs frame integrity across an emulated circuit channel.

For example, given a 2x64 kbit/s emulated circuit, two octets that are sent into the input IWF's Service Interface in one 125 us frame shall be delivered at the output IWF's Service Interface in one frame, and in the same order.
- R7. The Nx64 service MAY support variable bit rate operation, where temporarily inactive timeslots are dynamically suppressed.

8.1.3 Multiplexing Support

- R8. The Nx64 Service MAY provide aggregation of multiple small Nx64 services into a larger Nx64 service. This aggregation will normally take place in the TDM domain using standard TDM multiplexing techniques, and is intended to provide a multi-point to point type service.
- R9. The Nx64 Service MAY provide decomposition of a large Nx64 service into several smaller Nx64 services. This decomposition will normally take place in the TDM domain using standard TDM de-multiplexing techniques, and is intended to provide a point to multi-point type service.

8.1.4 Clocking

The DS1 and E1 Nx64 kbit/s Service requires the use of synchronous circuit timing. In order to support this synchronous clock recovery by the attached end-user equipment, the following requirements are stated:

- R10. Any Nx64 Service IWF SHALL provide a means by which a timesource traceable to a Primary Reference Source (PRS) may be supplied.
- R11. For DS1 Service, an IWF Service Interface SHALL provide 1.544 MHz \pm 32 ppm timing to external DS1 equipment.
- R12. For E1 Nx64 Service, an IWF Service Interface SHALL provide 2.048 MHz \pm 50 ppm timing to external E1 equipment.

These requirements assume that the IWF provides the required synchronous circuit timing to the external equipment via the CES service interface itself. Note, however, that this does not preclude the provision of the synchronous circuit timing to the external equipment via a separate physical interface. The specification of such a separate timing interface is beyond the scope of this specification. Section 7.3 gives more information about clock distribution techniques.

8.1.5 Jitter and Wander

- R13. Jitter measured at the output of the IWF Service Interface and tolerated at the input of the IWF Service Interface MUST meet [T1.403] and [G.824] for DS1 circuits.
- R14. Wander MUST meet [T1.403] and [G.824] for DS1 circuits.
- R15. Jitter measured at the output of the IWF Service Interface and tolerated at the input of the IWF Service Interface MUST meet [G.823] for E1 circuits.
- R16. Wander MUST meet [G.823] for E1 circuits.

8.1.6 Facility Data Link

This section applies only to DS1 ESF Nx64 service.

- R17. The CES IWF SHALL terminate the Facility Data Link (FDL) as specified in [T1.403]
- R18. DS1 Performance-related information from T1.403-compliant FDL messages SHALL be communicated to the management system. DS1 ESF FDL messages which are not Link Management messages as defined in [T1.403] MAY be ignored by the IWF.

8.1.7 Bit Oriented Messages

This section applies only to DS1 Nx64 service.

- R19. For DS1 using ESF, the IWF MUST terminate Bit Oriented Messages for Yellow Alarms and loopback as described in [T1.403].

8.1.8 Alarms

- R20. The IWF SHALL detect Loss of Signal (LOS), AIS or Yellow conditions, loss of frame synchronisation, and loss of multi-frame synchronisation and report these conditions to the management system.
- R21. When LOS, Out-of-Frame or AIS occur, the IWF SHALL apply Trunk Conditioning in the downstream direction. Procedures for Trunk Conditioning are described in Bellcore TR-NWT-000170 Issue 2, Section

- 2.5. A Remote Alarm Indication (RAI, or 'yellow') SHALL be delivered in the upstream direction. The exact maintenance actions required to be performed depend on the application and environment being served.
- R22. When RAI is received at the Service Interface, the IWF SHALL apply trunk conditioning in the downstream direction only.

8.1.9 Signaling Bits

- R23. All Nx64 Service IWFs SHALL provide Basic Service. This mode is compatible with N-ISDN applications, as well as many video codecs.
- R24. Nx64 Service IWFs MAY also provide Nx64 Service with CAS. This mode is required for much existing PBX and voice telephony equipment.

8.1.10 Lost and Out of Sequence Frames

- R25. If an Ethernet frame does not arrive in time to be played out on the TDM service interface, the Nx64 service at the egress of the MEN SHALL insert data into the TDM data stream consisting of the same number of octets of data as the previous frame. The content of the inserted octets is implementation-dependent. If the Ethernet frame subsequently arrives, it SHALL be discarded.
- R26. In case of persistent loss or late arrival of Ethernet frames, the CE-bound IWF SHALL signal this condition back to the MEN-bound IWF.
- R27. If an out-of-sequence Ethernet frame is detected, the Nx64 service at the egress of the MEN MAY re-order the frames to insert it in the correct place. Alternatively, it MAY discard the frame, and insert data into the TDM data stream consisting of the same number of octets of data as the discarded frame. The content of the inserted octets is implementation-dependent.

8.1.11 Buffer Overflow/Underflow

- R28. The Nx64 Service IWF at the egress of the MEN SHALL perform controlled frame slips if it encounters an overflow or underflow (i.e. "data starvation") condition. The data inserted in case of underflow is implementation-dependent.
- R29. After an integration period, a persistent data starvation condition SHALL trigger Trunk Conditioning, as specified in Bellcore TR-NWT-000170. The length of integration period is recommended to be 2.5 ± 0.5 s.
- R30. All buffer overflow and underflow conditions SHALL be reported to the management system.

8.2 DS1/E1 UNSTRUCTURED SERVICE

DS1/E1 Unstructured CBR service is intended to emulate a point-to-point DS1 or E1 circuit. The service is accessed via either a 1.544 Mbit/s DSX-1 interface or a 2.048 Mbit/s [G.703] interface. The service is defined as a "clear channel pipe", transparently carrying any arbitrary 1.544 Mbit/s (2.048 Mbit/s for E1) data stream. The end-user timing source for these interface signals is not necessarily traceable to a PRS.

Note that framing formats other than standard SF, ESF or [G.704] formats cannot be supported by all PDH/SDH installed equipment. If CES service for such non-standard framing formats is offered by an exchange carrier, the carrier may have difficulty in maintaining the service interface due to the lack of facility support for operations and maintenance functions such as performance monitoring, facility loopbacks and so forth.

The DS1/E1 Unstructured Service also provides an optional feature that allows non-intrusive performance monitoring of the link if SF or ESF [G.704] framing is used.

8.2.1 Framing

- R31. The DS1/E1 Unstructured Service SHALL carry any arbitrary 1.544 Mbit/s \pm 32 ppm (2.048 Mbit/s \pm 50 ppm for E1) data stream.
- R32. Optionally, the Unstructured service MAY include a non-intrusive performance monitoring function that will decode but not terminate SF or ESF [G.704] framing.

The functions this option is intended to support are the collection of performance statistics, and detection of frame-based alarms and messages. There must be a configuration option to disable the performance monitor for use with unframed signals.

8.2.2 Clocking

The DS1/E1 Unstructured Service has two modes for timing user equipment attached to the Service Interface:

1. Synchronous Mode, in which timing is supplied to the attached DS1/E1 equipment via the IWF Service Interface, and may be traceable to a Primary Reference Source.
 2. Asynchronous Mode, in which timing is supplied by an independent clock in the attached equipment and carried transparently through the MEN network.
- R33. A CES IWF MUST implement at least one of the two clocking modes for DS1/E1 Unstructured Service, and MAY offer both modes. Two Interworking Functions must be configured for the same clocking mode in order to inter-operate.
- R34. If Asynchronous Mode is used, timing SHALL be properly accepted from user equipment as long as that timing is within \pm 32 ppm for DS1 (as specified in [T1.403]), \pm 50 ppm for E1 (as specified in [G.703]).

8.2.3 Jitter and Wander

Jitter and Wander may be present at the output of the emulated circuit, introduced, for example, by imperfections in clock recovery at the output of the CES IWF. Wander requirements apply to network-synchronous signals (i.e., those traceable to a PRS) but the same requirements may be applied to an asynchronous signal if the wander is defined as relative to the clock source rather than to an absolute reference.

- R35. Jitter measured at the output of the IWF Service Interface and tolerated at the input of the IWF Service Interface SHALL meet [T1.102] and [G.824] for DS1 circuits with any clocking mode.
- R36. Jitter measured at the output of the IWF Service Interface and tolerated at the input of the IWF Service Interface SHALL meet [G.823] for E1 circuits with any clocking mode.

8.2.4 Facility Data Link

- R37. The Facility Data Link associated with the Service Interface, if present, SHALL NOT be modified by the Unstructured Service Interface.
- R38. If the optional performance monitoring feature is enabled, the Interworking Function SHALL monitor Performance Report Messages as described in [T1.403]. The collected statistics SHALL be reported to the management system.

8.2.5 Alarms

- R39. For DS1 or E1 Unstructured Service, all alarms received at the input of the Service Interface MUST be carried through to the output Service Interface without modification.

- R40. The IWF SHALL detect Loss of Signal (LOS) at the TDM Service Interface of the MEN-bound IWF. This condition SHALL be signaled to the CE-bound IWF.
- R41. If the optional performance monitoring feature is provided for the DS1 or E1 Unstructured Service, the CES Interworking Function SHALL monitor the alarm status of the Service Interface. Alarm status shall be reported to the management system.

8.2.6 *Lost and Out of Sequence Frames*

- R42. If Ethernet frame does not arrive in time to be played out on the TDM service interface, the Unstructured DS1/E1 Service IWF at the egress of the MEN SHALL insert an implementation-dependent pattern into the TDM data stream consisting of the same number of octets of data as the previous frame. If the Ethernet frame subsequently arrives, it SHALL be discarded.
- R43. In case of persistent loss or late arrival of Ethernet frames, the CE-bound IWF SHALL signal this condition back to the MEN-bound IWF.
- R44. If an out-of-sequence Ethernet frame is detected, the Unstructured DS1/E1 Service IWF at the egress of the MEN MAY re-order the frames to insert it in the correct place. Alternatively, it MAY discard the frame, and insert an implementation-dependent pattern into the TDM data stream consisting of the same number of octets of data as the discarded frame.
- R45. A CES IWF SHOULD attempt to minimise any effect on loss of synchronisation with the underlying TDM multiframe structure (if present) caused by loss of Ethernet frames in the MEN.

8.2.7 *Buffer Overflow/Underflow*

- R46. The Unstructured DS1/E1 Service IWF at the egress of the MEN SHALL insert an all-ones pattern if it encounters an underflow (i.e., "data starvation") condition.
- Note: This condition may result in a reframe event for DS1/E1 equipment using the Unstructured service.
- R47. After an integration period, a persistent data starvation condition SHALL trigger a Loss of Frames fault indication, resulting in downstream AIS. The length of integration period is recommended to be 2.5 ± 0.5 s.
- R48. The Unstructured DS1/E1 Service IWF at the egress of the MEN SHALL drop an implementation-dependent number of bits if it encounters an overflow condition.
- R49. All buffer overflow and underflow conditions SHALL be reported to the management system.

8.3 UNSTRUCTURED DS3/E3 SERVICE

Unstructured DS3/E3 Service is intended to emulate a point-to-point DS3 or E3 circuit. The service is accessed via either a 44.736 Mbit/s DSX-3 interface or a 34.368 Mbit/s [G.703] interface. The service is defined as a "clear channel pipe", transparently carrying any arbitrary 44.736/34.368 Mbit/s data stream. The end-user timing source for these interface signals is not necessarily traceable to a PRS.

Note that framing formats other than standard DS3 or E3 formats cannot be supported by all PDH/SDH installed equipment. If CES service for such non-standard framing formats is offered by an exchange carrier, the carrier may have difficulty in maintaining the service interface due to the lack of facility support for operations and maintenance functions such as performance monitoring, facility loopbacks and so forth.

8.3.1 *Framing*

- R50. The Unstructured DS3/E3 Service SHALL carry any arbitrary 44.736/34.368 Mbit/s ± 20 ppm data stream.

8.3.2 Clocking

The Unstructured DS3/E3 Service has two modes for timing user equipment attached to the Service Interface:

1. Synchronous Mode, in which timing is supplied to attached DS3/E3 equipment via the IWF Service Interface, and may be traceable to a Primary Reference Source.
 2. Asynchronous Mode, in which timing is supplied by attached equipment and carried through the MEN network.
- R51. A CES IWF MUST implement at least one of the two clocking modes for Unstructured DS3/E3 Service, and MAY offer both modes. Two Interworking Functions must be configured for the same clocking mode in order to interoperate.
- R52. If Asynchronous Mode is used, timing SHALL be properly accepted from user equipment as long as that timing is within ± 20 ppm (as specified in [T1.102] for DS3 and in [G.703] for E3).

8.3.3 Jitter and Wander

Jitter and Wander may be present at the output of the emulated circuit, introduced, for example, by imperfections in clock recovery at the output of the CES IWF.

Wander requirements apply to network-synchronous signals (i.e., those traceable to a PRS) but the same requirements may be applied to an asynchronous signal if the wander is defined as relative to the clock source rather than to an absolute reference.

- R53. Jitter measured at the output of the IWF Service Interface and tolerated at the input of the IWF Service Interface SHALL meet [T1.102] and [G.824] for DS3 circuits with any clocking mode.
- R54. Jitter measured at the output of the IWF Service Interface and tolerated at the input of the IWF Service Interface SHALL meet [G.823] for E3 circuits with any clocking mode.

8.3.4 Alarms

- R55. For Unstructured DS3/E3 Service, all alarms received at the input of the Service Interface SHALL be carried through to the output Service Interface without modification.
- R56. The IWF SHALL detect Loss of Signal (LOS) at the IWF Service Interface. Upon detection of LOS, the segmenting IWF shall send Ethernet frames containing an AIS pattern (all-ones for E3, framed 1010... for DS3 as specified in [T1.107]) downstream.

8.3.5 Lost and Out of Sequence Frames

- R57. If Ethernet frame does not arrive in time to be played out on the TDM service interface, an Unstructured DS3/E3 Service IWF at the egress of the MEN SHALL insert an implementation-dependent pattern into the TDM data stream, consisting of the same number of octets of data as the previous frame. If the Ethernet frame subsequently arrives, it SHALL be discarded.
- R58. In case of persistent loss or late arrival of Ethernet frames, the CE-bound IWF SHALL signal this condition back to the MEN-bound IWF.
- R59. If an out-of-sequence Ethernet frame is detected, an Unstructured DS3/E3 Service IWF at the egress of the MEN MAY re-order the frames to insert it in the correct place. Alternatively, it MAY discard the frame, and insert an implementation-dependent pattern into the TDM data stream, consisting of the same number of octets of data as the discarded frame.
- R60. A CES IWF SHOULD attempt to minimise any effect on loss of synchronisation with the underlying TDM frame structure (if present) caused by loss of Ethernet frames in the MEN.

8.3.6 Buffer Overflow/Underflow

R61. An Unstructured E3 Service IWF at the egress of the MEN SHALL insert an all-ones pattern if it encounters an underflow (i.e., “data starvation”) condition.

Note: This condition may result in a reframe event for E3 equipment using this service.

R62. An Unstructured DS3 Service IWF at the egress of the MEN SHALL insert a framed DS3 AIS pattern if it encounters an underflow (i.e., “data starvation”) condition. The inserted data shall form a continuous framed DS3 AIS pattern as long as contiguous data must be inserted. This pattern need not be aligned with the original DS3 signal.

Note: This condition may result in a reframe event for DS3 equipment using this service.

R63. After an integration period, a persistent data starvation condition for an Unstructured E3 Service SHALL trigger generation of an AIS pattern (all ones) downstream. The length of integration period is recommended to be 2.5 ± 0.5 s.

R64. After an integration period, a persistent data starvation condition for an Unstructured DS3 Service SHALL trigger the generation of a continuous framed DS3 AIS (framed 1010...) downstream. The framing of this DS3 AIS SHALL be a continuous extension of the framing of the DS3 AIS being inserted while the starvation condition was being integrated. The length of integration period is recommended to be 2.5 ± 0.5 s.

R65. The Unstructured DS3/E3 Service IWF at the egress of the MEN SHALL drop an implementation-dependent number of bits if it encounters an overflow condition.

R66. All buffer overflow and underflow conditions SHALL be reported to the management system.

8.4 SONET/SDH INTERFACES

8.4.1 Framing and Overhead Processing

R67. An IWF providing PDH emulation services SHALL follow the standard SDH/SONET mapping procedures as defined in [G.707] and [GR-253-CORE]

R68. The IWF SHALL terminate regenerator section (section layer in SONET terminology) and multiplex section (line layer in SONET terminology) when providing structured SDH/SONET emulation.

R69. The IWF SHALL operate as a wire passing all SDH/SONET circuit bytes across the MEN when providing unstructured SDH/SONET emulation.

R70. The IWF SHALL terminate HOVC Path (path layer in SONET terminology) when providing LOVC services.

R71. The IWF SHALL carry any arbitrary payload within the virtual container.

R72. The IWF MAY provide optimised emulation treatment depending on the payload carried within the virtual container. For example, the SDH/SONET IWF MAY suppress sending payload for unequipped virtual containers.

R73. The IWF MAY monitor the SONET/SDH overhead bytes, and in particular the signal label bytes (C2, V5), and provide optimised emulation treatment depending on the monitored values. For example, the IWF MAY determine that the virtual container is in AIS state and decide to suppress sending payload until AIS condition is cleared.

K1, K2 Line overhead bytes are used to exchange Automatic Protection Switching (APS) requests and acknowledgements between APS controller of Line Termination Equipments (LTE). IWF providing unstructured SDH/SONET emulation carry all line overhead bytes across the MEN unmodified, including K1 and K2 bytes.

The MEN protection requirements include sub 50 milliseconds protection schemes including 1+1 and 1:1 protection. Failure indications and protection switching request received from the SDH/SONET line can be translated to triggers and protection indication for the MEN protection mechanism.

R74. IWF providing Structured SDH/SONET emulation MAY provide mechanisms to bridge between SDH/SONET APS channel messages received from CE and MEN protection triggering and indications.

S1 Line overhead byte carries Synchronization Status Messages (SSM). The SSM messages contain clock quality labels that allow an SDH/SONET NE to select the most suitable synchronization reference from the set of available references. There are three primary criteria for selecting a source for primary reference [T1.101]: Quality level, network path of the timing signal and facility availability.

Recovering reference clock from the incoming Ethernet frames should always be selected as the last option, due to the relatively high noise (delay variation) of the incoming signal. In other words, the network path of the timing signal criteria is more significant than the quality level. The usefulness of carrying the S1 byte across the MEN is therefore limited for situations where the IWF needs to select between two signals recovered from the MEN. In these situations, the dominant factor would once more be the relative amount of delay variations experienced by the two signals across the MEN, and not necessarily the quality level. Successful switching according to SSM messages depends on the reaction time of each LTE and the SDH/SONET topology in non-emulated networks. For these reasons, SSM signaling and reference switching due to SSM messages in SDH/SONET circuit emulation services is left for future study.

R75. The Structured SDH/SONET IWF recovering reference clock from the Ethernet frames SHALL set the S1 byte (CE bound) to either quality level 2 (traceability unknown), user assigned quality level or quality level 9 (don't use for synchronization).

R76. SDH/SONET CE connected to an unstructured SDH/SONET IWF SHALL be configured not to process SSM messages on the interface from the IWF, if the IWF recovers the clock from the incoming Ethernet frames.

Structured SDH/SONET emulation terminates the regenerator section and multiplex section (line). The line overhead bytes include DCC channels (D1-D12 and F byte) used for Remote Terminal NE management, for orderwire channel, etc. Structured SDH/SONET emulation does not carry the overhead bytes within the emulated circuit stream.

SDH/SONET LTE terminates the line DCC channel, and analyzes the remote terminal management messages received. The DCC channel includes remote management messages intended for the LTE, as well as messages intended to other LTEs. The LTE routes the remote terminal messages destined to other LTEs by sending these messages via the appropriate DCC channels of its outgoing SDH/SONET interfaces. STE terminate the section DCC channel, and process the remote terminal messages in the same way.

Transaction Language 1 (TL1) is the management protocol defined for managing SDH/SONET NEs. With the success of the Internet Protocol, the use of the IP management protocol, SNMP, became popular also in managing SDH/SONET networks. The DCC channel may therefore include either TL1 messages or IP and SNMP messages used for remote terminal management.

An LTE should therefore support remote terminal management through the DCC channels. The IWF should be able to route the DCC messages destined to other SDH/SONET NE (including remote IWFs) across the MEN. The IWF should provide this bridging function.

R77. An SDH/SONET IWF SHOULD provide a bridge for remote terminal management messages received from the SDH/SONET line across the MEN and back.

8.4.2 Clocking

Four SDH/SONET Network Elements (NEs) timing modes are defined (GR-253-CORE section 5.4.3). The timing mode determines the source of timing for OC-N/STM-N electrical signals transmitted by the NE. The timing modes are:

1. External Timing: The preferred timing mode via external BITS
2. Line Timing (from CE): Timing is recovered from one of the CE lines

3. Line Timing (from MEN): Timing is recovered from the MEN.
 4. Through Timing: Timing of CE-bound interface is derived by MEN-bound interface and vice versa.
 5. Free running: Stand alone mode. IWF uses its internal oscillator.
- R78. The IWF for structured SDH/SONET SHALL support external, line (from CE) and free running timing modes
- R79. The IWF for structured SDH/SONET emulation MAY support line (from MEN) timing mode.
- R80. The IWF for unstructured SDH/SONET emulation SHALL support line (from CE) timing mode and MAY support through timing mode. Through timing mode SHALL use either external timing reference or recover the service clock from the MEN.

Two options for SDH Equipment Clock (SEC) are defined in [G.813]. The first option, referred to as Option 1, applies to SDH networks optimized for the 2048 kbit/s hierarchy. The second option, referred to as Option 2, applies to SDH networks optimized for the particular 1544 kbit/s hierarchy that includes the rates 1544 kbit/s, 6312 kbit/s, and 44 736 kbit/s.

The options defined for SONET clocks are Stratum-3 as defined in [GR-1244-CORE], and [T1.101] and SONET Minimal Clock (SMC) as defined in [T1.105.09]. SMC is equivalent to SDH Option 2 SEC, while Stratum-3 clock is equivalent to Type IV clock as defined in [G.812] which is slightly better than SDH Option 1 SEC. [GR-1244-CORE] defines the clocks for synchronized networks starting for Stratum-1 and down to Stratum-4. Enhanced Stratum clocks are also defined, including Stratum-3e which have better performance in terms of holdover and wander filtering.

The SEC used in SDH/SONET emulation IWF depends on the functionality of the IWF and its place within the network. When SDH/SONET emulation IWF provides PDH service emulation, the requirements on the SEC are minimal. In scenarios where the IWF provides PDH to SDH emulation, or when the IWF provides SDH to SDH emulation the requirements are more stringent.

- R81. The IWF SHALL have internal clock of ± 20 ppm minimum free run accuracy.
- R82. IWF providing HOVC service SHALL support either Option 2 (SMC) SEC or Stratum 3 clock. The IWF SHALL have internal clock of ± 4.6 ppm minimum free run accuracy..
- R83. SDH emulation IWF MAY support Option 1 SEC.

8.4.3 Pointer Adjustments

Both SDH and SONET utilize payload pointers to carry the signal. The payload pointer gives the location of the beginning of the payload within the SDH/SONET structure. Differences in phase and frequency between two SDH/SONET NEs (Network Elements) can be handled by the use of payload pointers. If the sending SDH/SONET NE is faster than the receiving NE, the receiving NE will introduce a negative pointer adjustment and shift the payload ahead by one byte. In this manner, the receiving NE can keep up with the sending NE without loss of information. Similarly, if the sending NE is slower than the receiving NE a positive pointer adjustment of one byte is introduced. Pointer adjustments may be used by the IWF for adjusting to retime the emulated circuits in the same manner.

- R84. SDH/SONET IWFs MAY retime virtual containers by generating pointer adjustments.
- R85. SDH/SONET Structured IWFs SHALL have the option to carry pointer adjustment indications received from the SDH/SONET interface across the MEN.

SDH and SONET standards define Pointer Adjustment Counters (PJC) for performance monitoring and for detection of degraded service. SDH/SONET structured emulation IWF need to provide the same function

- R86. SDH/SONET emulation IWF SHALL provide PJC counters for positive and negative pointer adjustment generated and replayed at the IWF.

Pointer adjustments introduce jitter and wander on the payload carried within their containers. The major impact on DS1 and E1 payloads is wander, while the major impact on DS3 and E3 payload is jitter. The amount of pointer adjustments introduced by the IWF should therefore be minimal.

R87. The IWF SHALL provide a mechanism to limit the pointer adjustment generated or relayed.

8.4.4 Jitter and Wander

Jitter and Wander may be present at the output of the emulated circuit, introduced, for example, by imperfections in clock recovery at the output of the CES IWF.

Wander requirements apply to network-synchronous signals (i.e. those traceable to a PRS) but the same requirements may be applied to an asynchronous signal if the wander is defined as relative to the clock source rather than to an absolute reference.

R88. Jitter measured at the output of the IWF Service Interface and tolerated at the input of the IWF Service Interface SHALL meet [GR-253-CORE], [T1.105.03] and [G.825] for SDH/SONET STM-1/OC-3 and STM-4/OC-12 circuits with any clocking mode.

R89. Jitter measured at the output of the IWF Service Interface providing PDH services SHALL meet the respective PDH standards ([G.823], [G.824] and [T1.102]) for any clocking mode.

R90. Jitter and Wander Generation of the IWF SHALL stand within the specification of [G.783], [GR-253-CORE] and [T1.105.03] for STM-1/OC-3 and STM-4/OC-12 circuits.

8.4.5 Alarms

R91. IWF providing HOVC services SHALL detect and handle all alarms at the regenerator and multiplex sections as defined in [G.707] and [GR-253-CORE].

R92. IWF providing LOVC services SHALL detect and handle all alarms at the regenerator, multiplex and higher order path sections as defined in [G.707] and [GR-253-CORE].

R93. IWF providing PDH services SHALL detect and handle mapping of alarms at the PDH service interface (LOF, LOS, etc) to indications at the LOVC overhead bytes, as defined in [G.707] and [GR-253-CORE].

8.4.6 Buffer Overflow/Underflow

The re-assembly function will require a buffer in which the re-assembled data stream is stored before it is transmitted out the Service Interface. The size of this buffer will be implementation dependent, but it must be large enough to accommodate expected MEN packet jitter, while small enough to not introduce excessive delay in the emulated circuit.

R94. The IWF SHALL play out a replacement packet towards the CE bound interface if the jitter buffer is empty or the packet to be played out has not been received.

R95. The IWF SHALL declare Loss of Packet Synchronization (LOPS) defect when it encounters more than a configurable number of missing packets.

R96. The IWF SHALL declare Loss of Packet Synchronization (LOPS) failure after 2.5 +/- 0.5 seconds of LOPS defect, and cleared after 10 seconds free of LOPS defect state. The circuit is considered down as long as LOPS failure is declared

R97. The IWF SHALL play out an all-one pattern if LOPS defect is declared

R98. The egress IWF SHALL send a Remote Defect Indication (RDI) to the ingress IWF when LOPS defect is declared.

R99. All buffer overflow and underflow conditions SHALL be reported to the management system.

8.5 GENERAL REQUIREMENTS

8.5.1 Loopbacks

R100. The CES interworking function SHALL support service loopbacks via in-band signaling (transmission of specific digital pattern in the TDM channel encapsulated by the emulation) and by request of the IWF Element Management System.

R101. The following provider-controlled-service loopbacks SHALL be supported:

- a. At/near the TDM Network Demarcation, i.e., at a point within the provider's network as close as practicable to the Network Demarcation. Loopbacks at this interface SHALL comply with the ANSI/ITU loopback specifications for the appropriate TDM interface level (e.g., [T1.403] for a DS1 interface).
- b. At the TDM service interface (i.e., loopback TDM egress traffic into the TDM ingress port).

R102. The following provider-controlled-service loopbacks MAY be supported:

- a. At the Ethernet frame egress side (i.e., loopback of transmitted frames into the frame ingress port).
- b. At the Ethernet frame ingress (i.e., loopback of frames received from the MEN back into the MEN towards the source device).

R103. The following customer-controlled-service loopbacks MAY be supported:

- a. At the TDM interface of the local CE.
- b. At the TDM interface of the remote CE.

8.5.2 Frame Loss and Reordering

R104. In order to minimize effect of occasional loss of an Ethernet frame on the egress service, the encapsulation layer:

- a. SHALL allow independent interpretation of TDM data in each specific Ethernet frame by the CE-bound IWF (see [RFC 2736]). This requirement MAY be disregarded if the CE-bound IWF has to interpret structures that exceed the path MTU between the MEN-bound and CE-bound PEs.
- b. SHALL allow reliable detection of lost Ethernet frames.
- c. SHOULD allow prediction (within reasonable limits) of the arrival time of the next Ethernet frame and detection of lost packets that takes such a prediction into account.
- d. SHOULD allow reordering of Ethernet frames if the frame is not judged to be too late. Out-of-order frames judged to be too late MUST be discarded.
- e. SHALL minimize possible effect of lost Ethernet frames on recovery of the circuit clock by the CE-bound IWF depending on the actual network synchronization scheme deployed.
- f. SHALL NOT require re-transmission of Ethernet frames containing TDM payload

R105. The IWF SHALL record all lost Ethernet frames and report this statistic to the Management System

8.5.3 Efficiency

R106. The CES solution SHOULD try to minimize the network delay and network bandwidth needed for transporting the TDM traffic.

R107. The CES solution SHALL enable the MEN provider to favor efficiency over network delay and vice-versa, by being able to define the size of TDM bitstream transmitted in each packet.

9. MEN Requirements

To ensure proper operation of the CES IWF the MEN will have to provide certain levels of service quality. These level are defined as follows:

9.1 FRAME DELAY

End-to-end delay requirements are application-specific. End-to-end delay requirements are beyond the scope of this specification. Delay sensitive applications will include voice services and 2 way video services such as video conferencing. In these cases delay in a MEN shall be kept to a minimum by specifying that Ethernet Virtual Circuits that carry delay sensitive CES traffic be given the highest service priority to avoid queuing of data in intermediary network switches.

R108. In order to avoid the need for voice echo cancellation, the Frame Delay across the MEN for an emulated circuit SHOULD be less than 25 ms.

Frame Delay is defined as “the maximum delay measured for a percentile (P) of successfully delivered in profile (green) Service Frames over a time interval (t1)”. This means that a small percentile of frames will have longer delay than the frame delay parameter in a service level specification. This percentile will contribute to the Frame Error Ratio described in sections 7.5.1 and 9.3. Therefore, any percentile on frame delay quoted in a service level specification will need to be of the order of 99.9999% or higher, in order to meet the ES or SES requirement on the TDM circuit. The exact percentile will need to be worked out from figures quoted in section 7.5, and taking into account the level of frame loss and frame jitter.

R109. In order to meet the ES and SES requirements on a PDH circuit, the Frame Delay parameter in the service level specification for an emulated TDM circuit SHOULD be quoted with a percentile sufficient to exceed the Frame Error Ratios shown in Figure 17 and Figure 19 (sections 7.5.3 and 7.5.4).

R110. In order to meet the ES, SES and BBER requirements on a SONET/SDH circuit, the Frame Delay parameter in the service level specification for an emulated TDM circuit SHOULD be quoted with a percentile sufficient to exceed the Frame Error Ratios shown in Table 15, section 7.5.5.

9.2 ETHERNET FRAME JITTER

Ethernet frame jitter (variation in frame inter-arrival time) will hinder the recovery of the clock synchronization if adaptive clock recovery techniques are used. As well the play-out buffer in the receiver IWF must be sized to prevent underflow and overflow conditions based, to some degree, on the amount of frame jitter than is present. This queuing delay adds delay to the end to end TDM service. The following recommendations are a guide to the level of frame jitter that the IWF should be capable of tolerating:

R111. The CES IWF SHOULD be capable of functioning correctly when used in conjunction with MEN Ethernet Virtual Circuits with a Frame Jitter of up to 10 ms.

Frame Jitter is defined as “the Frame Delay for a measurement interval (t1) and a percentile (P), minus the service frame delay of the service frame with the lowest service frame delay in the Frame Delay population”. Therefore, as with frame delay above, any service level specification for an emulated circuit should use percentiles of the order of 99.9999% or higher, in order to meet the ES or SES requirement on the TDM circuit.

R112. In order to meet the ES and SES requirements on a PDH circuit, the Frame Jitter parameter in the service level specification for an emulated TDM circuit SHOULD be quoted with a percentile sufficient to exceed the Frame Error Ratios shown in Figure 17 and Figure 19 (sections 7.5.3 and 7.5.4).

R113. In order to meet the ES, SES and BBER requirements on a SONET/SDH circuit, the Frame Jitter parameter in the service level specification for an emulated TDM circuit SHOULD be quoted with a percentile sufficient to exceed the Frame Error Ratios shown in Table 15, section 7.5.5.

9.3 ETHERNET FRAME LOSS

As described in section 7.5.1, there are three performance parameters defined for an EVC that may appear collectively as Ethernet frame loss to the CES Interworking Function. These are: Frame Loss, Frame Delay and Frame Jitter. In addition any bit errors induced in the data flow across the MEN will also have an impact on the TDM service, although there is no performance metric defined to measure this within the MEN.

The collective sum of all the above errors (frame loss, excess frame jitter and bit errors) can be aggregated into a single measure termed "Frame Error Ratio" (FER), defined as the total of all effects leading to the loss of or discarding of a frame.

Service performance for PDH circuits is measured in terms of Errored Seconds (ES) and Severely Errored Seconds (SES). Performance objectives for Errored Seconds and Severely Errored Seconds are given in [T1.510], [T1.503], and [G.826]. The relationship between these objectives and the collective Frame Error Ratio is derived in section 7.5.

R114. In order to meet the Errored Seconds objective for PDH circuits, the Ethernet Frame Error Ratio SHALL meet the requirements of Figure 17 in section 7.5.3.

R115. In order to meet the Severely Errored Seconds objective for PDH circuits, the Ethernet Frame Error Ratio SHALL meet the requirements of Figure 19 in section 7.5.4.

R116. In order to meet the Errored Seconds objective for SDH/SONET circuits, the Ethernet Frame Error Ratio SHALL meet the requirements in the CES FER column of Table 15, section 7.5.5.

R117. In order to meet the Severely Errored Seconds objective for SDH/SONET circuits, the Ethernet Frame Error Ratio SHALL meet the requirements the CES SESFER column of Table 15, section 7.5.5.

R118. In order to meet the Background Block Errored Ratio objective for SDH/SONET circuits, the Ethernet Frame Error Ratio SHALL meet the requirements the CES BFER column of Table 15, section 7.5.5.

9.4 NETWORK AVAILABILITY

Section 7.5.6 gives guidance as to the Frame Error Ratio that may cause a TDM service to become unavailable according to the availability definitions in the relevant TDM standards. Network availability objectives for TDM circuits are specified in [T1.510] for DS1 and DS3, [G.827] for E1, E3 and SDH, and [T1.514] for SONET.

R119. An EVC SHALL have sufficient quality to support an availability ratio on the TDM service of 99.95% or better when used to carry emulated TDM services.

9.5 BANDWIDTH PROVISIONING

R120. In order to be able to provision bandwidth efficiently for an emulated circuit, the MEN SHOULD be able to provision bandwidth in increments of 100 kbit/s or smaller.

10. References

Reference	Reference Details
RFC 1958	“Architectural Principles of the Internet”, RFC 1958, B. Carpenter (ed.), June 1996, http://www.ietf.org/rfc/rfc1958.txt
RFC 2119	“Key words for use in RFCs to Indicate Requirement Levels”, RFC 2119, S. Bradner, March 1997, http://www.ietf.org/rfc/rfc2119.txt
RFC 2736	“Guidelines for Writers of RTP Payload Format Specifications”, RFC 2736, M. Handley & C. Perkins, December 1999, http://www.ietf.org/rfc/rfc2736.txt
ATM CES	“Circuit Emulation Services Interoperability Specification, Version 2.0”, ATM Forum af-vtoa-0078.000, January 1997, ftp://ftp.atmforum.com/pub/approved-specs/af-vtoa-0078.000.pdf
G.703	“Physical/electrical characteristics of hierarchical digital interfaces”, ITU-T recommendation G.703, October 1998
G.704	“Synchronous Frame Structures used at 1544, 6312, 2048, 8448 and 44736 Hierarchical Levels”, ITU-T recommendation G.704, October 1998
G.707	“Network node interface for the Synchronous Digital Hierarchy (SDH)”, ITU-T recommendation G.707,
G.775	“Loss of signal (LOS), Alarm Indication Signal (AIS) and Remote Defect Indication (RDI) defect detection and clearance criteria for PDH signals”, ITU-T recommendation G.775, October 1998
G.783	“Characteristics of synchronous digital hierarchy (SDH) equipment functional blocks”, ITU-T recommendation G.783, October 2000
G.812	“Timing Requirements Of Slave Clocks Suitable For Use As Node Clocks In Synchronization Networks”, ITU-T recommendation G.812, June 1998
G.813	“Timing characteristics of SDH equipment slave clocks (SEC)”, ITU-T recommendation G.813, March 2003
G.823	“The control of jitter and wander within digital networks which are based on the 2048 kbit/s hierarchy”, ITU-T recommendation G.823, March 2000
G.824	“The control of jitter and wander within digital networks which are based on the 1544 kbit/s hierarchy”, ITU-T recommendation G.824, March 2000
G.825	“The control of jitter and wander within digital networks which are based on the synchronous digital hierarchy”, ITU-T recommendation G.825, March 2000
G.826	“Error performance parameters and objectives for international, constant bit rate digital paths at or above the primary rate”, ITU-T recommendation G.826, February 1999
G.827	“Availability performance parameters and objectives for international, constant bit rate digital paths at or above the primary rate”, ITU-T recommendation G.827, September 2003
M2101.1	“Performance Limits for bringing-into-service and maintenance of international SDH paths and multiplex section”, ITU-T recommendation M.2101.1, April 1997
GR-253-CORE	“Synchronous Optical Network (SONET) Transport Systems: Common Generic Criteria”, Telcordia Technologies, GR-253-CORE, Issue 3, September 2000
GR-1244-CORE	“Clocks for the Synchronized Network: Common Generic Criteria”, Telcordia Technologies, GR-1244-CORE, Issue 2, December 2000
T1.101	“Synchronization Interface Standard”, ANSI T1.101-1999

Reference	Reference Details
T1.102	“Digital Hierarchy – Electrical Interfaces”, ANSI T1.102-1993
T1.105.03	“Synchronous Optical Network (SONET): Jitter at Network Interfaces”, ANSI T1.105.03-1994
T1.105.09	“Synchronous Optical Network (SONET): Network Timing and Synchronization”, ANSI T1.105.09-1996
T1.107	“Digital Hierarchy Formats Specifications”, ANSI T1.107-2002
T1.403	“Network and Customer Installation Interfaces – DS1 Electrical Interface”, ANSI T1.403-1999
T1.404	“Network-to-Customer Installation – DS3 Metallic Interface Specification”, ANSI T1.404-1994
T1.503	“Network Performance Parameters for Dedicated Digital Services – Definitions and Measurements”, ANSI T1.503-2002
T1.510	“Network Performance Parameters for Dedicated Digital Services for Rates up to and including DS3”, ANSI T1.510-1999
T1.514	“Network Performance Parameters and Objectives for Dedicated Digital Services – SONET Bit Rates”, ANSI T1.514-2001