



Technical Specification

MEF 12

Metro Ethernet Network Architecture Framework

Part 2: Ethernet Services Layer

April 2005

Disclaimer

The information in this publication is freely available for reproduction and use by any recipient and is believed to be accurate as of its publication date. Such information is subject to change without notice and the Metro Ethernet Forum (MEF) is not responsible for any errors. The MEF does not assume responsibility to update or correct any information in this publication. No representation or warranty, expressed or implied, is made by the MEF concerning the completeness, accuracy, or applicability of any information contained herein and no liability of any kind shall be assumed by the MEF as a result of reliance upon such information.

The information contained herein is intended to be used without modification by the recipient or user of this document. The MEF is not responsible or liable for any modifications to this document made by any other party.

The receipt or any use of this document or its contents does not in any way create, by implication or otherwise:

- (a) any express or implied license or right to or under any patent, copyright, trademark or trade secret rights held or claimed by any MEF member company which are or may be associated with the ideas, techniques, concepts or expressions contained herein; nor
- (b) any warranty or representation that any MEF member companies will announce any product(s) and/or service(s) related thereto, or if such announcements are made, that such announced product(s) and/or service(s) embody any or all of the ideas, technologies, or concepts contained herein; nor
- (c) any form of relationship between any MEF member companies and the recipient or user of this document.

Implementation or use of specific Metro Ethernet standards or recommendations and MEF specifications will be voluntary, and no company shall be obliged to implement them by virtue of participation in the Metro Ethernet Forum. The MEF is a non-profit international organization accelerating industry cooperation on Metro Ethernet technology. The MEF does not, expressly or otherwise, endorse or promote any specific products or services.

© The Metro Ethernet Forum 2005. All Rights Reserved.

Table of Contents

1. ABSTRACT	1
2. TERMINOLOGY	1
3. SCOPE	2
4. COMPLIANCE LEVELS	2
5. THE ETHERNET SERVICES LAYER	2
5.1 ETH LAYER CHARACTERISTIC INFORMATION	3
5.2 ETH LAYER TOPOLOGICAL COMPONENTS.....	4
5.2.1 <i>ETH Layer Network</i>	5
5.2.2 <i>ETH Flow Domain</i>	5
5.2.3 <i>ETH Link</i>	6
5.2.4 <i>ETH Access Group</i>	6
6. ETH LAYER NETWORK REFERENCE MODEL	6
6.1 ETHERNET VIRTUAL CONNECTION (EVC)	9
6.2 ETH LAYER FUNCTIONAL ELEMENTS.....	9
6.2.1 <i>APP to ETH Adaptation Function (EAF)</i>	10
6.2.2 <i>ETH Flow Termination Function (EFTF)</i>	10
6.3 ETH CONDITIONING FUNCTIONAL ELEMENTS	11
6.3.1 <i>ETH Flow Conditioning Function (EFCF)</i>	11
6.3.2 <i>ETH Subscriber Conditioning Function (ESCF)</i>	12
6.3.3 <i>ETH Provider Conditioning Function (EPCF)</i>	12
6.4 ETH EVC ADAPTATION FUNCTION (EEAF).....	13
6.5 ETH EVC TERMINATION FUNCTION (EETF).....	13
6.6 ETH CONNECTION FUNCTION (ECF)	14
6.7 ETH TO TRAN ADAPTATION FUNCTION (TAF).....	14
7. ETH LINKS	15
7.1 ETH ACCESS LINK.....	15
7.2 ETH TRUNK LINK.....	17
8. REFERENCES	19

APPENDIX I - REFERENCE MODEL FOR IEEE BRIDGES	20
I.1 IEEE 802.1D MODEL.....	20
I.2 IEEE 802.1Q BRIDGE MODELS.....	20
I.3 IEEE P802.1AD BRIDGE MODEL.....	21

List of Figures

Figure 1: ETH Layer Interfaces and Reference Points.....	3
Figure 2: ETH Layer Characteristic Information (ETH_CI).....	4
Figure 3: ETH Layer topological components.....	5
Figure 4: Scope of an ETH Flow Domain	6
Figure 5: Basic ETH Layer Network Reference Model (single Service Provider).....	9
Figure 6: Reference model of an ETH Access Link for direct attachment of an ETH UNI-C to an UNI-N.....	16
Figure 7: Reference model of ETH Access Links for indirect attachment of an UNI-C to an UNI-N via a SNI from a TMF	17
Figure 8: Reference model of an ETH Trunk Link between two I-NNIs.....	18
Figure 9: Reference model of an ETH Access Link among E-NNIs.....	19
Figure 10: Basic IEEE 802.1D Bridge Model.....	20
Figure 11: Basic IEEE 802.1Q Bridge Model	21
Figure 12: Basic IEEE P802.1ad Bridge Model.....	22

List of Tables

Table 1: Summary of ETH Layer Topological Components, Transport Entities and Reference Points	5
---	---

1. Abstract

This document is a contribution to the Technical Committee of the Metro Ethernet Forum. This document provides architectural framework to model the Ethernet Services Layer – ETH Layer- of MEF compliant Metro Ethernet Networks (MENs). The ETH Layer architecture framework describes the high-level constructs used to model the various architectural components, their functional elements, and their interconnect relationships. The framework also describes the relationship between ETH Layer functional elements and reference points to other architectural elements in the Transport (TRAN) and Application (APP) layers of the MEF Generic Architecture Framework (MEF 4 [13]).

2. Terminology

Term	Definition
APP	Application Layer
BWP	Bandwidth Profile
C-VLAN	Customer VLAN
CE	Customer Edge
CI	Characteristic Information
CFI	Canonical Format Indicator
CoS	Class of Service
CoS ID	Class of Service Identifier
DP	Discard Priority
EAF	ETH Adaptation Function
ECF	ETH Connection Function
ECT	Ethernet Connectionless Trail
EETF	ETH EVC Termination Function
EFD	ETH Flow Domain
EFCF	ETH Flow Conditioning Function
EFTF	Ethernet Flow Termination Function
EPCF	ETH Provider Conditioning Function
ESCF	ETH Subscriber Conditioning Function
ETH	Ethernet Services Layer
EtherType	Ethernet Length/Type
EVC	Ethernet Virtual Connection
FCS	Frame Check Sequence
FPP	Flow Point Pool
L2CP	Layer Two Control Protocols
LAN	Local Area Network
LLC	Logical Link Control
MAC	Media Access Control
MCF	MAC Convergence Function
MEN	Metro Ethernet Network
MIF	MAC Independent Function
NE	Network Element
NNI	Network-Network Interface

Term	Definition
PCS	Physical Coding Sub-layer
PDU	Protocol Data Unit
PE	Provider Edge
P-VLAN	Provider VLAN
S-VLAN	Service VLAN (also referred to as Provider VLAN)
TAF	Transport Adaptation Function
TCI	Tag Control Information
TRAN	Transport Layer
UNI	User-Network Interface
UNI-C	UNI Client
UNI-N	UNI Network
VLAN	Virtual LAN
VLAN ID	VLAN Identifier
VPLS	Virtual Private LAN Service
WAN	Wide Area Network

3. Scope

The Ethernet Services Layer architecture framework provides the generic model used by the MEF to describe architectural components and functional elements that enable and support Ethernet-centric service-aware capabilities of a MEN. The document is intended to describe the decomposition model for a MEN in terms of the access and core service-enabling functions, their relationships to ETH Layer functional elements, and the interconnect rules among them. The framework is also intended to describe the interactions of the ETH Layer with the TRAN and APP layers across well-defined external interfaces and reference points. The ETH Layer architecture framework is not intended to require, or exclude, any specific networking technology from being used on any given implementation of a MEN. Yet, the framework provides the generic interconnect and information transfer guidelines to facilitate specification of interoperable ETH Layer components for UNIs and I-NNIs/E-NNIs conforming to this architecture model. Detailed Technical Specifications and Implementation Agreements for specific architectural elements are outside the scope of this document.

4. Compliance Levels

The key words "MUST", "MUST NOT", "REQUIRED", "SHALL", "SHALL NOT", "SHOULD", "SHOULD NOT", "RECOMMENDED", "MAY", and "OPTIONAL" in this document are to be interpreted as described in RFC 2119 [1]. All key words must be use upper case, bold text.

5. The Ethernet Services Layer

The Ethernet Services Layer, also referred to as the ETH Layer, is the specific layer network within a MEN responsible for the instantiation of Ethernet MAC oriented connectivity services and the delivery of Ethernet PDUs presented across well-defined internal and external interfaces. The ETH Layer is responsible for all service-aware aspects associated with Ethernet MAC flows, including operations, administration, maintenance and provisioning capabilities required to support Ethernet connectivity services. As per the MEF services model (MEF 10 [12]), the Service Frame presented by the ETH Layer external interfaces is expected to be an Ethernet unicast, multicast or broadcast frame conforming to the IEEE 802.3-2002 frame format [3].

Figure 1 shows the relationship between the MEN interfaces defined in the MEF Generic Architecture Framework (MEF 4 [13]) and the ETH Layer. From the perspective of the ETH Layer, only those components of the UNI/NNI related to Ethernet service-aware functions are relevant. The traffic units exchanged among these reference points are discussed in Section 5.1. From a functional modeling viewpoint, the Ethernet Services Layer Network consists of topological, transport and processing entities. The relevant ETH Layer topological and transport entities are described in Section 5.2.

A detailed reference model for ETH Layer is provided in Section 6. The model is based on a functional modeling description of the various MEN components. In particular, the ETH Layer processing entities (functional elements) are described in Section 6.2. This functional view is derived from ITU-T Recommendations G.809 and G.8010/Y.1306 [ITU G.809][ITU G.8010].

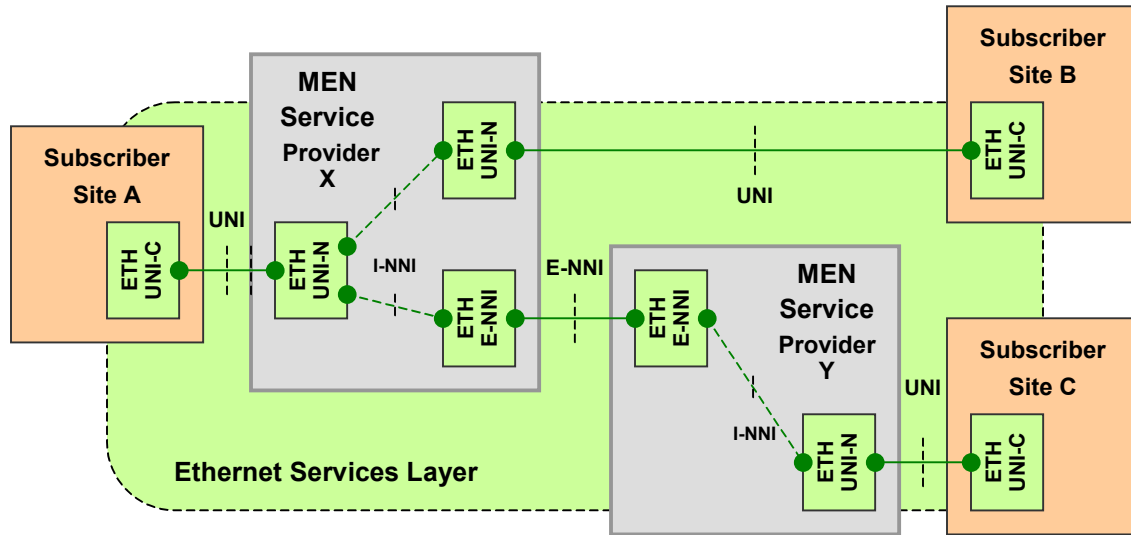

Figure 1: ETH Layer Interfaces and Reference Points

5.1 ETH LAYER CHARACTERISTIC INFORMATION

Functional models in ITU-T Recommendations G.809/G.8010 refer to the intrinsic information unit exchanged unaltered over a layer network as the Characteristic Information (CI) of layer network.

For the ETH Layer, the characteristic information unit exchanged over the ETH Layer links, the ETH_CI, consists of the following information elements from the IEEE 802.3-2002 MAC frame:

- Destination MAC Address (DA)
- Source MAC Address (SA)
- (Optional) 802.1QTag
- Ethernet Length/Type (EtherType)
- User Data

The optional four-octet 802.1QTag is composed of a two-octet 802.1QTagType and the Tag Control Information (TCI), which contains 3-bits of CoS/Priority information, the single-bit Canonical Format Indicator (CFI) and the 12-bit VLAN Identifier (VLAN ID). Note that the VLAN ID and CoS/Priority are optional information elements in any IEEE 802.3-2002 MAC frame. Note also that for the purposes of functional modeling VLAN ID values are viewed as internal constructs of the ETH Layer

network to help with partitioning (multiplexing) functions and, as such, are not considered part of the ETH_CI. CoS/Priority information, however, is viewed as an inherent characteristic of a flow/connection and, as such, part of the ETH_CI.

The User Data conveys the APP Layer PDU, either in a raw format or as a Logical Link Control (LLC) encapsulated PDU.

The term ETH Layer PDUs is used in this document to refer to the data frames used to exchange the ETH_CI across standardized ETH Layer interfaces and associated reference points. In particular, the Ethernet Service Frame (see MEF 10 [12]) refers to the ETH Layer PDU exchanged across the UNI. Operations on Service Frames to support the ETH Layer service model under the MEF services framework are further defined in MEF 10 [12]. Figure 2 illustrates the ETH_CI for common IEEE 802.3-2002 compliant frame formats.

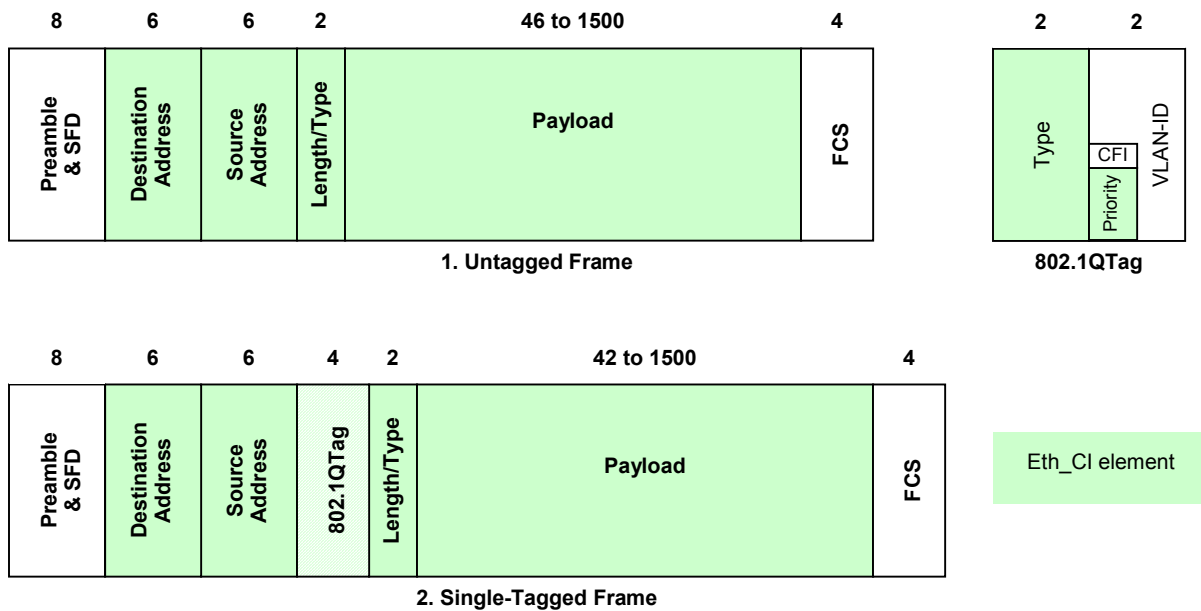

Figure 2: ETH Layer Characteristic Information (ETH_CI)

CoS/Priority information associated with a ETH Layer PDU may be conveyed implicitly via information derived from the fields in the ETH, APP layer PDUs or TRAN layer link identifiers, or explicitly from the information conveyed in the 3-bit Priority field (also referred to as the user_priority field [3]) of the Customer VLAN (C-VLAN) Tag. The interpretation of the explicit priority indications is specified in IEEE 802.1Q [4].

5.2 ETH LAYER TOPOLOGICAL COMPONENTS

Table 1 summarizes the ETH Layer topological components, transport entities, and reference points as defined in the ITU-T Recommendation G.8010 and the MEF Architecture Framework (MEF 4 [13]). Figure 3 illustrates the relationships among ETH Layer topological components.

Topological Components:	Transport Entities:	Reference Points
ETH Layer Network	ETH Network Flow	ETH Access Point
ETH Flow Domain	ETH Flow Domain Flow	ETH Termination Flow Point
ETH Link	ETH Link Flow	ETH Flow Point

ETH Access Group	ETH Connectionless Trail	ETH Flow Point Pool
		ETH Termination Flow Point Pool

Table 1: Summary of ETH Layer Topological Components, Transport Entities and Reference Points

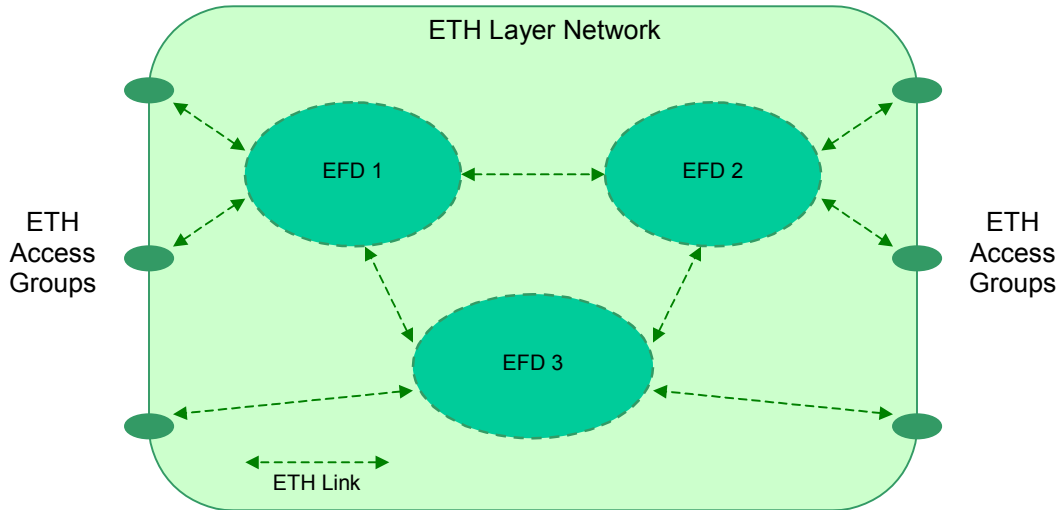

Figure 3: ETH Layer topological components

5.2.1 ETH Layer Network

The ETH Layer network is defined by the complete set of ETH access groups that may be associated for the purpose of transferring information between two or more access points. The scope of the ETH Layer network is the broadcast domain of all its access groups. The unit of information transferred within the ETH Layer is an ETH_CI. The association of two or more access points creates a connectionless transport entity referred to as the Ethernet Connectionless Trail (ECT). The resulting topology of the ETH Layer network can be described in terms of the set of all ETH access groups, the ETH flow domains and the ETH links¹ between them. This ETH Layer network view is illustrated in Figure 3.

5.2.2 ETH Flow Domain

An ETH Flow Domain (EFD) is a topological component defined by a set of all ETH (termination) flow points available for the purpose of transferring information within a given administrative portion of the ETH Layer network. EFDs may be partitioned into sets of non-overlapping EFDs interconnected by ETH links. A switching matrix (i.e., the ETH Layer function associated with an IEEE 802.1D bridge) represents the smallest instance of an EFD.

The scope of the EFD is the selective broadcast domain of the set of associated ETH (termination) flow points as illustrated in Figure 4. For instance, before MAC address learning occurs, an ETH Layer PDU received via an input port A (e.g., FP A) of the ETH flow domain is forwarded to all output ports on the EFD in (e.g., FP B, FP C and TFP D), with the exception of the output port that is in the same bi-directional ETH (termination) flow point as the input port (e.g., FP A).

¹ Also referred to as Flow Point Pool Link in G.809.

The connectivity among ETH (termination) flow points in an EFD is restricted by means of ETH network management or control plane actions.

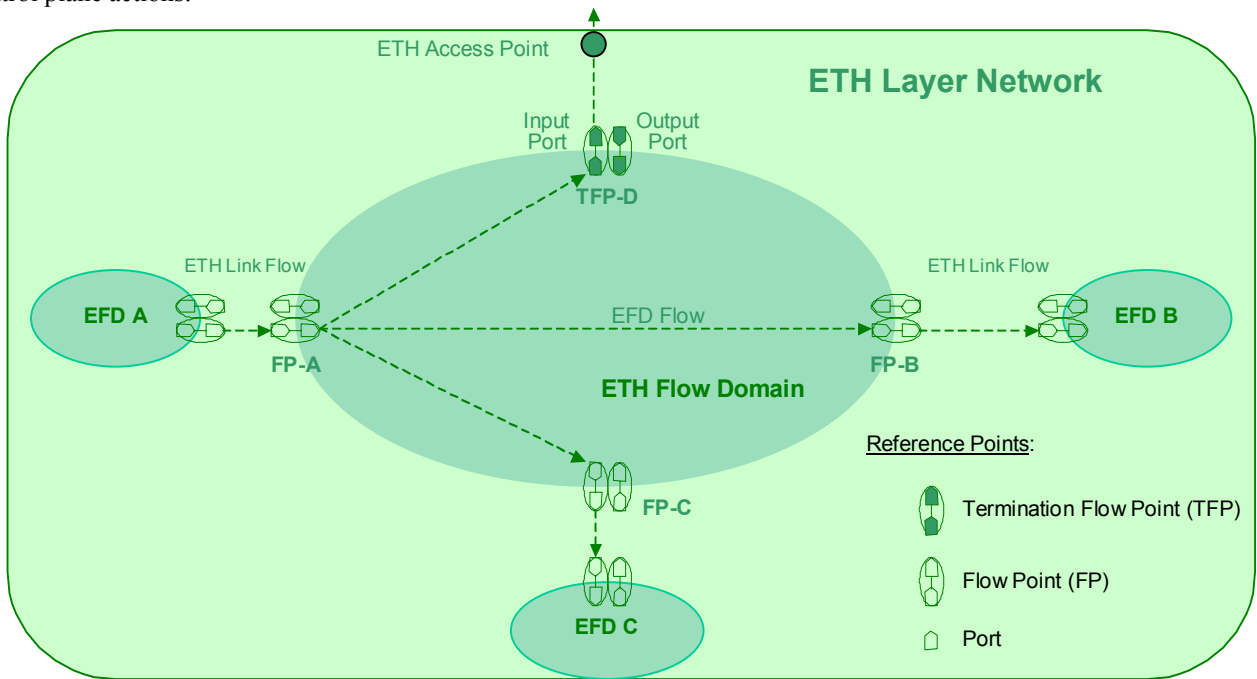

Figure 4: Scope of an ETH Flow Domain

5.2.3 ETH Link

The ETH link, also referred to as ETH flow point pool link (ETH FPP link), represents the topological relationship and available capacity between a set of reference points. Thus, an ETH link may interconnect:

- a set of ETH flow point pools at the edge of two EFDs, or
- a set of the ETH access points with a corresponding set of ETH flow points, or
- a set of ETH access points at the edge of another EFD, or
- an ETH access group for the purpose of transferring ETH_CI.

ETH links between EFDs are typically established at the timescale of the server Layer network. Section 7 provides a detailed functional model for ETH links.

5.2.4 ETH Access Group

An ETH access group is a group of co-located ETH flow termination functions that are connected to the same EFD or EFD link. The ETH access group demarcates the point of access into the ETH Layer network.

6. ETH Layer Network Reference Model

The ETH Layer network consists of Subscriber and Service Provider EFDs, ETH links (which include the layer’s adaptation functions), ETH flow termination functional elements that provide access to the client layer(s), and ETH functional elements

required to instantiate and manage ETH Layer flows, links and EVCs. As illustrated in Figure 5, there may be multiple independent EFDs (subnetworks) traversed by the EVCs.

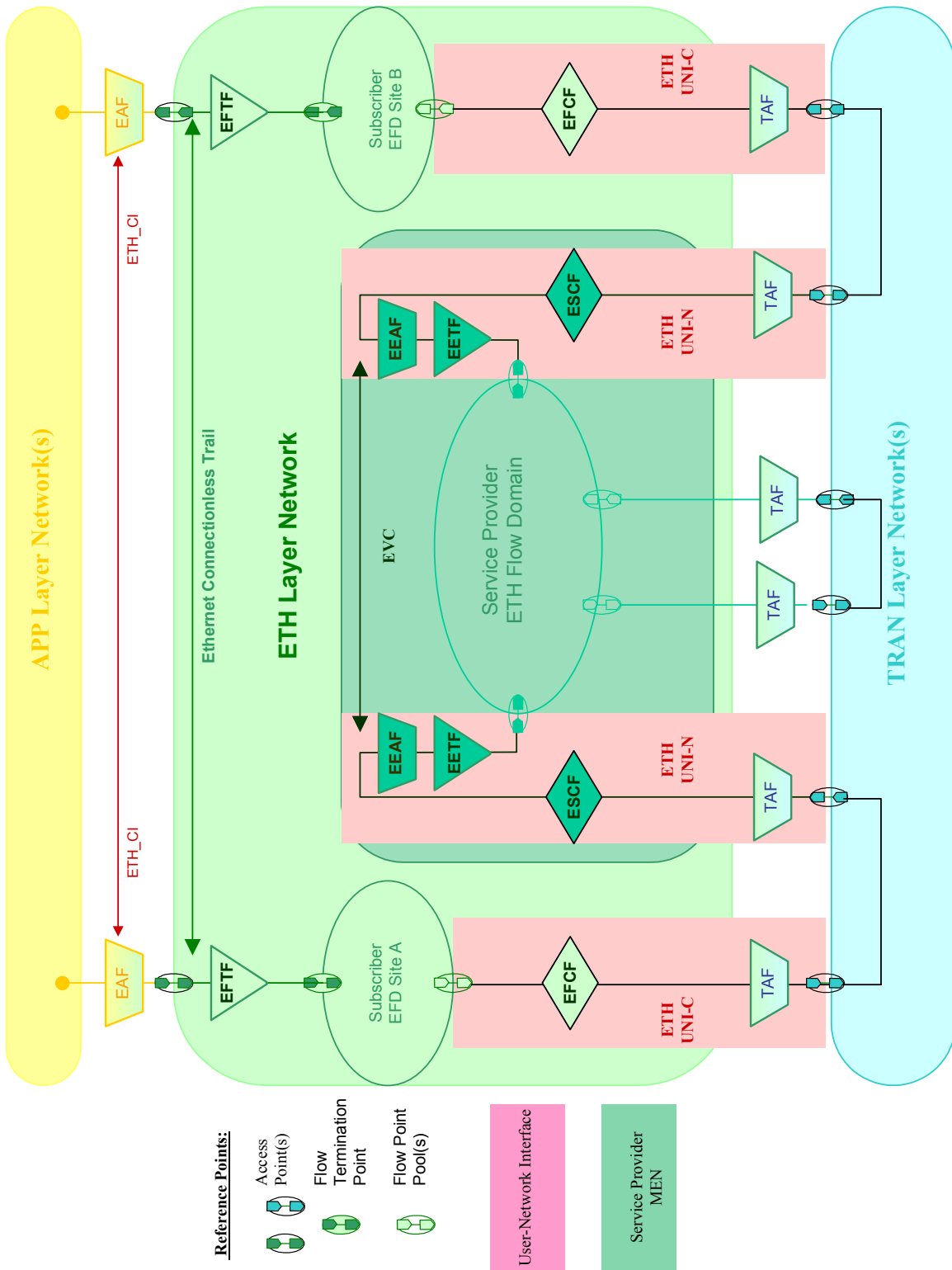

Figure 5: Basic ETH Layer Network Reference Model (single Service Provider)

The basic reference model consists of, at least, the following EFDs:

- the EFDs associated with the interconnected Subscriber sites (EFD Site A and EFD Site B) and
- the EFDs associated with the MEN Service Provider(s).

The partitioning of the ETH Layer network places bounds on the Ethernet services network functions. The ETH access links connect the Service Provider's ETH UNI-N to the subscriber equipment via the ETH UNI-C.

There may be multiple flow domains within the ETH Layer. At the coarsest level of granularity a flow domain represents a particular administrative domain within the ETH Layer. Examples are:

- a) Flow domains associated with the subscriber and the Service Provider networks (as illustrated in
- b) Figure 5).
- c) Flow domains associated with multiple Service Providers when an EVC traverses an E-NNI.
- d) Flow domains associated with different administrative/operational/maintenance boundaries within the same Service Provider.

6.1 ETHERNET VIRTUAL CONNECTION (EVC)

The EVC is the logical construct used to associate UNIs, and hence, enable the creation of an end-to-end subscriber services instances across one or more MEN Service Providers. An EVC is intended to represent a single instance of an ETH Layer service as specified in the MEF services definitions (MEF 6 [14]).

The following requirements apply to EVCs and its associated subscriber flows (see MEF 4, Sec 5 [13]):

- There **MUST** be a one-to-one relationship between an ETH Layer service instance and its associated EVC.
- Subscriber flows **MAY** be mapped into one or more EVCs across the same UNI (see Service Multiplexing Attribute (MEF 10 [12])).
- Subscriber flows corresponding to a single service instance **MUST** be mapped into a single EVC.
- For multiple subscriber flows mapped into a single EVC there **MAY** be multiple (delay/loss) CoS Instances associated to flows in the same EVC (see BWP per EVC and CoS ID Service Attributes in MEF 10 [12]).
- All flows mapped to an EVC **MUST** be forwarded along the ETH Connectionless Trail instantiated to support the selective broadcast domain for the EVC.
- For a given ETH Layer link, flows in an EVC **MAY** be forwarded over separate TRAN layer paths.

Rules to associate subscriber flows to UNIs and EVCs are described in the MEF services model (MEF 10 [12]).

EVCs are enabled at the UNI-N. Manual (e.g., UNI Type 1), management plane (see UNI Type 2) or control plane (UNI Type 3) mechanisms may be invoked to configure the mapping of Service Frames to EVCs between the UNI-C and its associated UNI-N.

6.2 ETH LAYER FUNCTIONAL ELEMENTS

The following ETH Layer functional elements are identified:

ETH Flow Termination Function (EFTF)

ETH Conditioning Functions:

- ETH Flow Conditioning Function (EFCF)
- ETH Subscriber Conditioning Function (ESCF)
- ETH Provider Conditioning Function (EPCF)

ETH EVC Adaptation Function (EEAF)
ETH EVC Termination Function (EETF)
ETH Connection Function (ECF)

Although not explicitly depicted in Figure 5 the ECF is the smallest instance of an EFD.

In addition, the following functional elements also support processing functions related to the ETH Layer, yet they are not fully contained within the ETH Layer:

APP to ETH Adaptation Functions (EAFs)
ETH to TRAN Adaptation function (TAFs)

In the sections below, some functional elements are defined as consisting of separate source and sink components (e.g., EETF, EEAF and TAF). This is the case for functional elements that add, and later remove, information elements to a flow for transport purposes. Other functional elements are defined as consisting of separate ingress and egress components (e.g., EFCF, ESCF and EPCF). This is the case for functional elements that just modify the information elements being conveyed by a flow. Thus different sets of processing functions apply to different client/server combinations (e.g., the TAF for Ethernet-over-Fiber is different from the TAF for Ethernet over SONET/SDH, see also ITU G.8010 [8]). The sections below describe each of these functional elements.

6.2.1 APP to ETH Adaptation Function (EAF)

The APP to ETH adaptation function (EAF) refers to a class of processing entities responsible for the adaptation of the APP layer PDUs to the ETH Layer. EAFs are application specific as there are multiple application client types (e.g., IP, voice, video, TDM, etc.) that may wish to make use of the ETH Layer services. The EAF supports the logical interface between APP layer and ETH Layer. The EAF consists of separate source and sink functions.

The source processes associated with the EAF Source function include:

- LLC PDU formation (if LLC is present)
- EtherType allocation as per client application and/or LLC type (if LLC is present)
- Any required padding to minimum transmission unit size
- Multiplexing of adapted client PDUs towards EETF

The sink processes associated with the EAF Sink function include:

- Demultiplexing of adapted client PDUs from EETF
- EtherType processing and decapsulation
- LLC PDU extraction (if LLC is present) and relaying to client process (as per EtherType)

6.2.2 ETH Flow Termination Function (EETF)

The ETH flow termination function refers to a class of processing entities in the ETH Layer responsible for the creation and termination of ETH network flows. The EETF supports the protocol interface between APP layer and ETH Layer. The EETF consists of separate source and sink functions.

The source processes associated with the EETF Source function include:

- Ethernet service frame preparation including:
 - Values for the Destination and Source MAC Address fields,
 - Option 802.1QTag (CE-VLAN-CoS value to be populated in the Priority field of the C-VLAN tag), and
 - User Data preparation

- Formatting of ETH Layer PDU (including any required OA&M information elements)
- Relaying of ETH Layer PDU toward target EFD

The sink processes associated with the EFTF Sink function include:

- Reception of the ETH Layer PDU from EFD
- Extraction of User Data (and potentially OA&M) information elements
- Relaying adapted client PDU to EAF

6.3 ETH CONDITIONING FUNCTIONAL ELEMENTS

The ETH conditioning functional elements refer to a class of processing entities responsible for classifying, filtering, metering, marking, policing, shaping and, in general, conditioning of flows into and out of the ETH Layer links between administrative network boundaries. Three types of ETH conditioning functions are identified: i) ETH flow conditioning function, ii) ETH subscriber conditioning function, and iii) ETH provider conditioning function. The role of each ETH conditioning functional elements is described in the next sections.

6.3.1 ETH Flow Conditioning Function (EFCF)

The ETH Flow Conditioning Function (EFCF) is the processing entity of the ETH Layer responsible for classification, filtering, metering, marking, policing, shaping and, in general, conditioning the Subscriber flow into and out of a Subscriber EFD. The EFCF consists of an ingress function operating on flows from the MEN and an egress function operating on flows to the MEN².

The egress processes associated with the EFCF Egress function include:

- Reception of candidate Ingress Service Frame from the Subscriber EFD
- Ingress Service Frame classification into one or more (e.g., Service Multiplexing) ingress flows as per rules defined in the MEF Services Model (MEF 10 [12])
- Ingress Service Frame conditioning towards the Service Provider EFD as applicable to ingress flow(s) as per contracted Ingress BWP including:
 - Metering,
 - Marking, and
 - Policing.
- Relaying the Ingress Service Frame to the TAF at the UNI-C

The ingress processes associated with the EFCF Ingress function include:

- Reception of Egress Service Frames from the TAF at the UNI-C
- Egress Service Frame classification (Optional) as applicable within the Subscriber EFD
- Egress Service Frame conditioning (Optional) as applicable within the Subscriber EFD including:
 - Metering,
 - Marking, and
 - Shaping.
- Relaying the Egress Service Frame towards the Subscriber EFD

² Note that the ECFC processes are named after the direction of the data flow at the UNI-C port where it is used. The egress process processes the frames going out at the UNI-C (egress direction) and the ingress process processes the frames coming in at the UNI-C (ingress direction). Service Frames, however, are named in relation to the MEN, hence, irrespective of the port (see MEF 10).

6.3.2 *ETH Subscriber Conditioning Function (ESCF)*

The ETH Subscriber Conditioning Function (ESCF) is the processing entity of the ETH Layer responsible for classification, filtering, metering, marking, policing, scheduling, shaping and, in general, conditioning the subscriber flow into and out of a Service Provider EFD. The ESCF consists of an ingress function operating of flows toward the MEN and an egress function operating on flows from the MEN.

The egress processes associated with the ESCF Egress function include:

- Reception of Egress Service Frame from the Service Provider EFD
- Egress Service Frame classification, including filtering, as per rules defined in the MEF services model (MEF 10 [12])
- Egress Service Frames conditioning towards the Subscriber EFD as per contracted Egress BWP including:
 - Metering,
 - Marking, and
 - Shaping.
- Relaying the Service Frames towards the TAF at the UNI-N

The ingress processes associated with the ESCF Ingress function include:

- Reception of Ingress Service Frame from the TAF at the UNI-N
- Ingress Service Frame classification, including filtering, as per rules defined in the MEF Services Model (MEF 10 [12]).
- CoS Instance determination as per contracted SLA
- Ingress Service Frame conditioning towards the Service Provider EFD including as per contracted Ingress BWP including:
 - Metering,
 - Marking, and
 - Policing.
- Ingress Service Frame Shaping as per Service Provider internal resource management requirements
- Relaying of the Egress Service Frames towards the Service Provider EFD

6.3.3 *ETH Provider Conditioning Function (EPCF)*

The ETH Provider Conditioning Function (EPCF) is the processing entity of the ETH Layer responsible for classification, filtering, metering, marking, policing, scheduling, shaping and, in general, conditioning flow(s) between two MENs. The EPCF supports ETH Layer traffic conditioning functions satisfying the flow classification and resource management requirements at the E-NNI. The EPCF consists of an ingress function operating on inbound flows to the MEN and an egress function operating on outbound flows from the MEN.

The ingress processes associated with the EPCF Ingress function include:

- Reception of Ingress Service Frame from the TAF at the E-NNI
- Ingress Service Frame classification, including filtering, as per rules defined in the MEF services model (MEF 10 [12])
- CoS Instance determination as per contracted SLA
- Ingress Service Frame conditioning as per contracted Ingress BWP including:
 - Metering,
 - Marking,
 - Policing.
- Ingress Service Frame Shaping as per Service Provider internal resource management requirements
- Relaying the Ingress Service Frame towards the Service Provider EFD

The egress processes associated with the EPCF Egress function include:

- Receiving Egress Service Frame from the Service Provider EFD
- Egress Service Frame classification, including filtering, as per rules defined in the MEF services model (MEF 10 [12])
- Egress Service Frame conditioning towards the target MEN as per contracted Egress BWP including:
 - Metering,
 - Marking, and
 - Shaping.
- Relaying the Egress Service Frame to the TAF at the E-NNI

6.4 ETH EVC ADAPTATION FUNCTION (EEAF)

The EEAF is the processing entity in the ETH Layer responsible for the adaptation of service frames into and out of EVCs. Thus, the EEAF may be viewed as a specialized instance of a “Flow Adaptation Function” for the purposes of instantiation of an EVC. The EEAF consists of separate source and sink functions.

The source processes associated with the EEAF Source function include:

- Mapping of conditioned Ingress Service Frames into their corresponding EVC PDUs
- Adaptation of the Subscriber CoS ID into Service Provider CoS indication as per contracted CoS instance
- Multiplexing Ingress Service Frames from various services instances into their corresponding EVC according to SLA (Optional)
- Ingress Service Frame traffic management functions including
 - Buffer management as per CoS Instance
 - Scheduling as per CoS Instance
- Relaying the Ingress Service Frame toward the EVC(s)

The sink processes associated with the EEAF Sink function include:

- De-multiplexing Egress Service frames from various EVCs into their corresponding service flow instances according to SLA (Optional)
- Adaptation of the Service Provider CoS information into the Subscriber CE-VLAN-CoS information, if applicable
- Relaying the Egress Service Frame toward the TAF at the UNI or E-NNI

When the EVC is implemented via TRAN layer trails the EEAF may not be present.

6.5 ETH EVC TERMINATION FUNCTION (EETF)

The EETF is the processing entity in the ETH Layer responsible for the creation and termination of EVC trails for the purposes of handling EVCs. Thus, the EETF may be viewed as a specialized instance of a “Flow Termination Function” for the purposes of instantiation of an EVC. The EETF consists of separate source and sink functions.

The source processes associated with the EETF Source function include:

- Multiplexing of management (e.g., OA&M), control and data plane PDUs
- Relaying of the adapted ETH Layer PDU towards the Service Provider EFD

The sink processes associated with the EETF Sink function include:

- Reception of the adapted EVC PDU from the Service Provider EFD

- De-multiplexing of management (e.g., OA&M), control and data plane PDUs

When the EVC trail consists of a single ETH layer link, the EETF may not be present.

6.6 ETH CONNECTION FUNCTION (ECF)

The ECF is the processing entity in the ETH Layer that affects the steering of the EVC PDUs within the MEN. The main role of the ECF is to switch traffic between ETH Layer links to facilitate the creation of point-to-point or multipoint connections³. Various connections models may be associated with an ECF. A sample list include:

- IEEE 802.1D Relay⁴
The ECF operates as an Ethernet frame relay as per IEEE 802.1D [4]
The ECF emulates a point-to-point link
- IEEE 802.1D Bridge⁵
The ECF operates as an Ethernet bridge as per IEEE 802.1D [4]
The ECF supports multipoint IEEE 802.1D based broadcast domain
- IEEE 802.1Q Bridge⁶
The ECF operates as an Ethernet VLAN bridge as per IEEE 802.1Q [5]
The ECF supports multipoint IEEE 802.1Q/VLAN based broadcast domain
- IEEE P802.1ad Bridge
The ECF operates as an Ethernet Provider bridge as per IEEE P802.1ad
The ECF supports multipoint IEEE P802.1ad/S-VLAN based broadcast domain
- IETF VPLS function The ECF emulates forwarding aspects of an IEEE 802.1D or an IEEE 802.1Q bridge as per the IETF L2VPN model Detailed models for each of these ECF implementations will be provided elsewhere.

6.7 ETH TO TRAN ADAPTATION FUNCTION (TAF)

The TAF refers to a class of processing entities responsible for the adaptation of the ETH Layer PDUs to its serving TRAN layer. TAFs are technology specific as there are multiple server layer network types (e.g., Ethernet, SONET/SDH, ATM, FR, MPLS, etc.) that may be used to instantiate the ETH Layer links. The TAF consists of separate source and sink processes.

The source processes associated with the TAF include:

- Buffering and scheduling of the ETH_CI information units
- Allocation of VLAN ID field value, if applicable
- Payload padding to meet minimum transmission unit size requirements for the server layer
- Generation of Service Frame FCS
- Encapsulation/encoding (e.g., adaptation) ETH_CI according to TRAN layer specific requirements, e.g.,
 - IEEE 802.3 [3]:
 - 8B/10B encoding

³ The term connection is used here in a loose sense. If the transport mode provided by the underlying layer network were connectionless the connection would be termed a network flow and the ECF would be termed an ETH flow domain function, in the ITU-T Rec. G.809/G.8010 sense.

⁴ The term ECF is also used here in a loose sense as the “relay” function may be emulated via TAFs.

⁵ Commonly used to realize enterprise FDs.

⁶ Commonly used to realize CoS-aware enterprise FDs.

- 4B/5B encoding
 - SDH/SONET:
 - GFP (ITU-T Recommendation G.7041) [9]
 - LAPS (ITU-T Recommendation X.86) [10]
 - ATM:
 - Multi-protocol over AAL5 encapsulation as per IETF RFC2684 [2]
 - ATM LAN encapsulation as per ATM Forum LANE specification [11]
 - IP/MPLS encapsulation as per IETF PWE3 model
- Multiplexing of EVC PDUs into ETH link
 Rate Adaptation into the TRANs layer
 Insertion of adapted ETH Layer data stream into payload of TRAN layer signal

The sink processes associated with the TAF include:

- Ethernet MAC frame FCS verification
- Ethernet MAC Frame filtering of subscriber frames not intended to be forwarded across the UNI
- Extraction of adapted ETH_CI from payload of the TRAN layer signal
- De-multiplexing of encapsulated EVC PDUs

7. ETH Links

As described in the Generic Architecture Framework (MEF 4 [13]), two link types are defined: Access Links and Trunk Links. This section discusses the relationship between the functional elements and the ETH Layer link types.

7.1 ETH ACCESS LINK

The main function of an ETH Access Link is to interconnect EFDs between two administrative entities. One example of such interconnect is the link between the port in the Subscriber's CE implementing the UNI-C processing functions to the port in Service Provider's PE implementing the UNI-N processing functions. Another example is the link between the ports of the PEs in two different Service Providers implementing the E-NNI processing function.

An ETH Access Link is instantiated via the following functional elements:

- On an UNI-C:
 - An ETH Flow Conditioning Function (EFCF)
 - A Transport Adaptation Function (TAF)
 - An underlying TRAN trail
- On an UNI-N:
 - An ETH Subscriber Conditioning Function (ESCF)
 - A Transport Adaptation Function (TAF)
 - An underlying TRAN trail

The following generic requirements apply to any ETH Access Links:

- There **MAY** be multiple flows and services instances from the same subscriber sharing the ETH Access Link.

The following requirements apply to any Access Link at the UNI-C:

- There **SHALL** be a one-to-one relationship between the ETH Access Link and its underlying TRAN link.

The following generic requirements apply to Access Links that directly attach an UNI-C to an UNI-N:

- The TRAN link supporting the ETH Access link **SHALL** be based on an IEEE 802.3 compliant PHY layer specification [3].
- There **SHALL** be a one-to-one relationship between a Subscriber and its ETH Access Link. Therefore, there cannot be multiplexing of Service Frames from different Subscribers onto the same ETH Access Link.

Figure 6 illustrates the relationships between the UNI functional elements and the associated ETH Access Link.

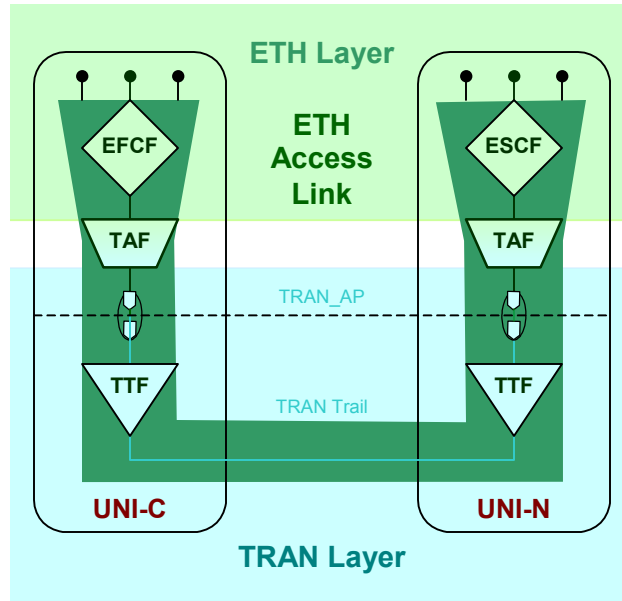

Figure 6: Reference model of an ETH Access Link for direct attachment of an ETH UNI-C to an UNI-N

Unless otherwise specified, the following requirements apply to any UNI-N indirectly attached to an UNI-C via a Transport Multiplexing Function (TMF):

- There **MAY** be a many-to-one relationship between the ETH Access Link and its underlying TRAN link.
- The ETH access link **MUST** be multiplexed via flow aggregation capabilities of the supporting TRAN layer. Logical integrity of the UNI-C/UNI-N ETH Access link **MUST** be preserved.

Figure 7 illustrates the relationships between the UNI functional elements and the associated ETH Access Link.

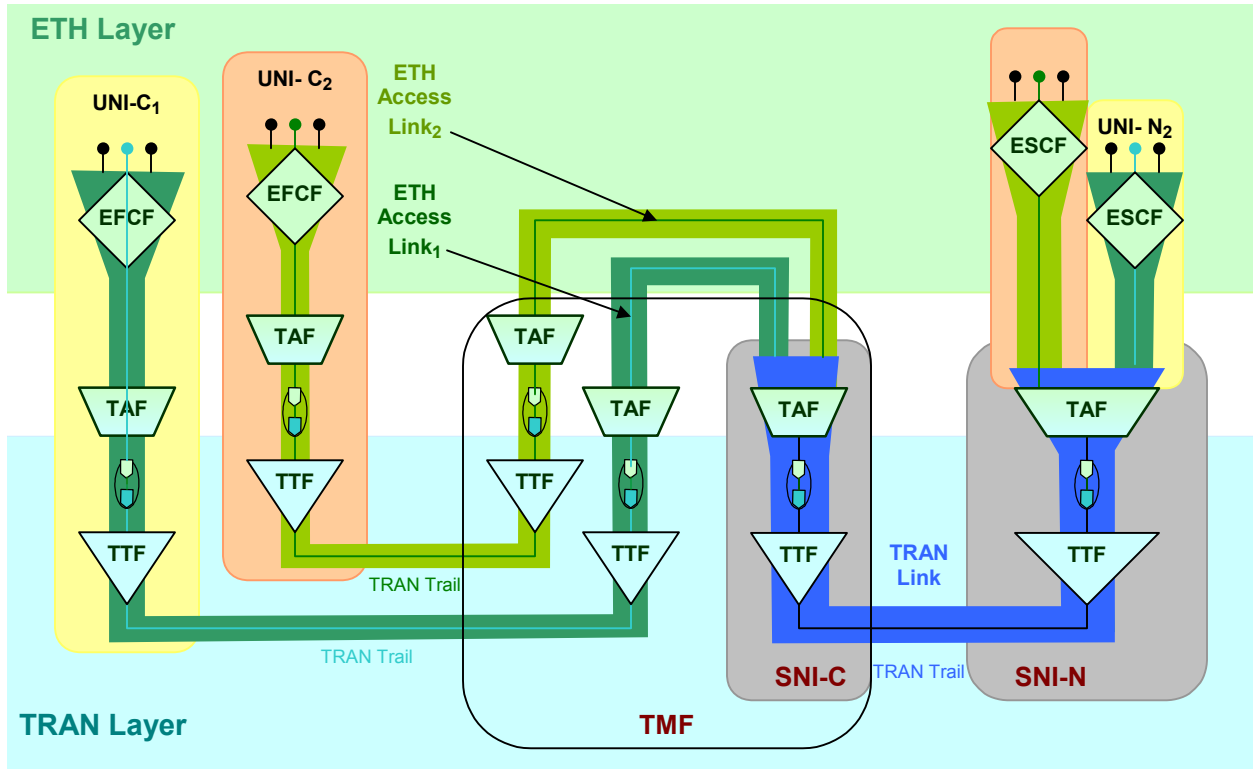

Figure 7: Reference model of ETH Access Links for indirect attachment of a UNI-C to a UNI-N via a SNI from a TMF

7.2 ETH TRUNK LINK

The main function of an ETH Trunk link is to interconnect ports between Service Provider NEs implementing the I-NNI processing functions.

An ETH Trunk Link is instantiated via the following functional elements:

- On an I-NNI:
 - A Transport Adaptation Function (TAF)
 - An underlying TRAN trail
- On an E-NNI:
 - An ETH Provider Conditioning Function
 - A Transport Adaptation Function (TAF)
 - An underlying TRAN trail

The following generic requirement apply to ETH Trunk Links:

- There **MAY** be a many-to-one relationship between EVCs and a given ETH Trunk Link.

The TRAN link supporting the ETH Trunk link may be instantiated via a variety of different technologies (IEEE 802.3, SONET/SDH EoS, RPR, ATM, MPLS, etc.)

The ETH Trunk Link implemented via an I-NNI includes the following functional elements:

- A TRAN Layer specific Transport Adaptation Function (TAF)
- An underlying TRAN Trail

Figure 8 illustrates the relationships between the an I-NNI and the associated ETH Trunk Link. Figure 9 illustrates the relationships between the E-NNI functional elements and the associated ETH Trunk Link.

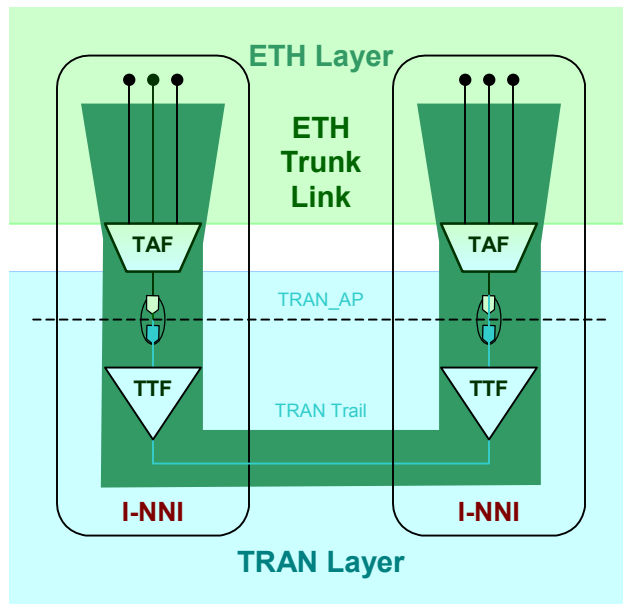

Figure 8: Reference model of an ETH Trunk Link between two I-NNIs

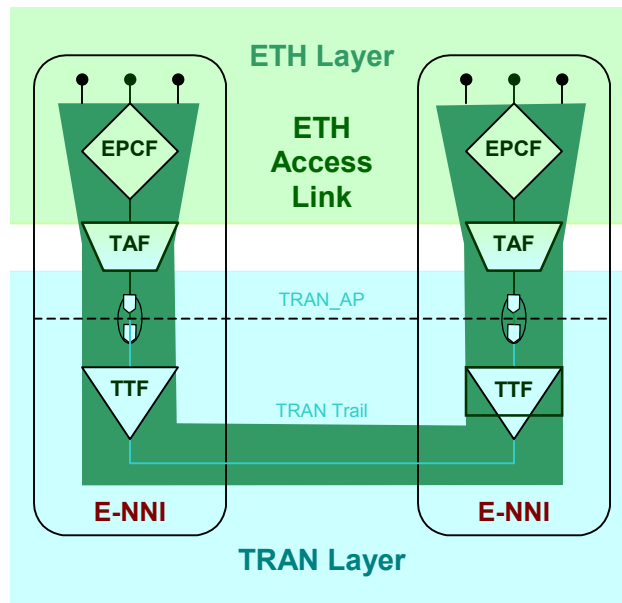

Figure 9: Reference model of an ETH Access Link among E-NNIs

Examples of TRAN trails are: SDH VC-n-Xv, SONET STS-n-Xv, IEEE 802.3 PHYs, ATM VCs, MPLS LSPs, etc.

8. References

- [1] IETF RFC 2119, "Key words for use in RFCs to Indicate Requirement Levels", S. Bradner,
- [2] IETF RFC 2684 "Multiprotocol Encapsulation over ATM Adaptation Layer," September 1999.
- [3] IEEE 802.3 - 2002, Information technology – Telecommunications and information exchange between systems – Local and metropolitan area networks – Specific requirements – Part 3: Carrier sense multiple access with collision detection (CSMA/CD) access method and physical layer specifications, March 2002.
- [4] IEEE 802.1D - 2004, "Media Access Control (MAC) Bridges." June 2004.
- [5] IEEE 802.1Q - 2003, "Virtual Bridged Local Area Networks." May 2003.
- [6] ITU-T Recommendation G.805 "Generic functional architecture of transport networks." March 2002.
- [7] ITU-T Recommendation G.809 "Functional architecture of connectionless layer networks." March 2003.
- [8] ITU-T Recommendation G.8010/Y.1306, "Architecture of Ethernet layer networks." February 2004.
- [9] ITU-T Recommendation G.7041/Y.1303, "Generic Framing Procedure (GFP)." December 2003.
- [10] ITU-T Recommendation X.886 "Ethernet over LAPS." February 2001.
- [11] ATM Forum, "LAN Emulation over ATM v1.0." January 1995.
- [12] Metro Ethernet Forum, MEF 10, "Ethernet Services Attributes, Phase 1." November 2004.
- [13] Metro Ethernet Forum, MEF 4, "MEN Architecture Framework – Part 1: Generic Framework." May 2004.
- [14] Metro Ethernet Forum, MEF 6, "Ethernet Services Definition, Phase 1." June 2004.

Appendix I - Reference Model for IEEE Bridges

(Informational)

I.1 IEEE 802.1D MODEL

Figure 10a illustrates the basic reference model for IEEE 802.1D Ethernet bridge as per the IEEE Ethernet bridge specification [IEEE 802.1D]. Figure 10b presents a mapping of the major IEEE 802.1D bridge components into the MEF ETH and TRAN layer functions.

The IEEE 802.1D Bridge ECF is specified as per the IEEE 802.1D MAC Relay function [IEEE 802.1D]. The IEEE 802.1D TAF (TAF-D) contains the MAC Convergence Function (MCF) (see [IEEE 802.1D] Section 6.5.1) as well as the aspects related to the mapping of the Ethernet MAC frame into the physical medium from the various blocks of the Physical Coding Sub-layer (PCS) in the IEEE 802.3 PHY specification [3].

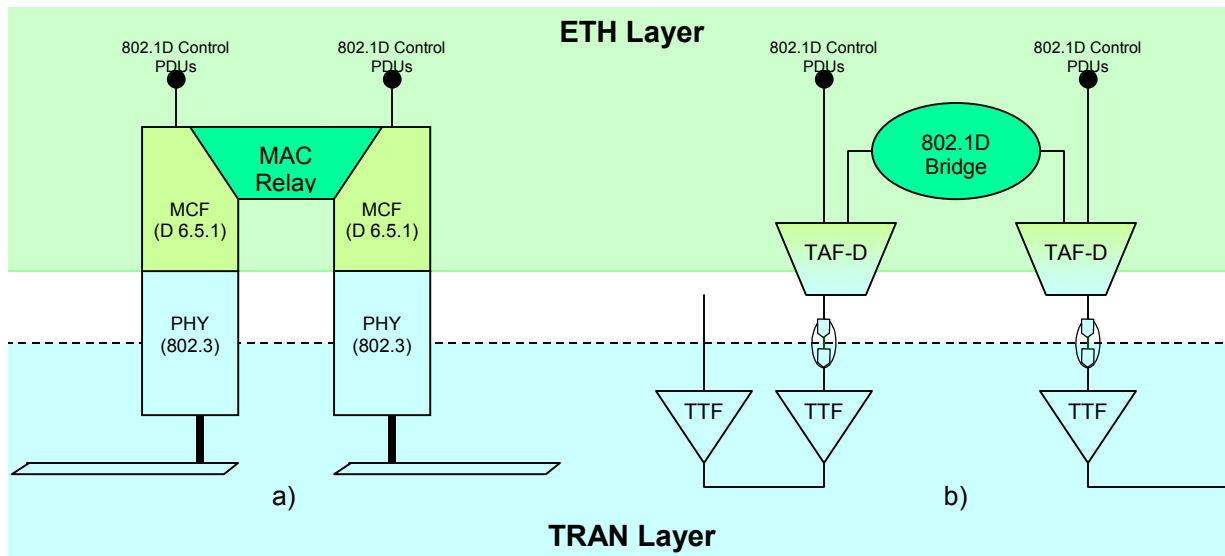

Figure 10: Basic IEEE 802.1D Bridge Model

I.2 IEEE 802.1Q BRIDGE MODELS

Figure 11 illustrates the reference model for an IEEE 802.1Q Ethernet VLAN bridge as per the IEEE VLAN Bridge specification [4]. Figure 11b presents a mapping of the major IEEE 802.1Q VLAN Bridge components into the MEF ETH and TRAN layer functions.

The IEEE 802.1Q Bridge ECF is specified by the IEEE 802.1Q MAC Relay function [4]. The IEEE 802.1Q TAF (TAF-Q) contains the Media Independent Functions (MIF) in IEEE 802.1Q Section 6.4.2, the MCF (IEEE 802.1D Section 6.5.1) functions as well as the aspects related to the mapping of the Ethernet MAC frame into the physical medium from the various blocks of the PCS in the IEEE 802.3 PHY specifications [3].

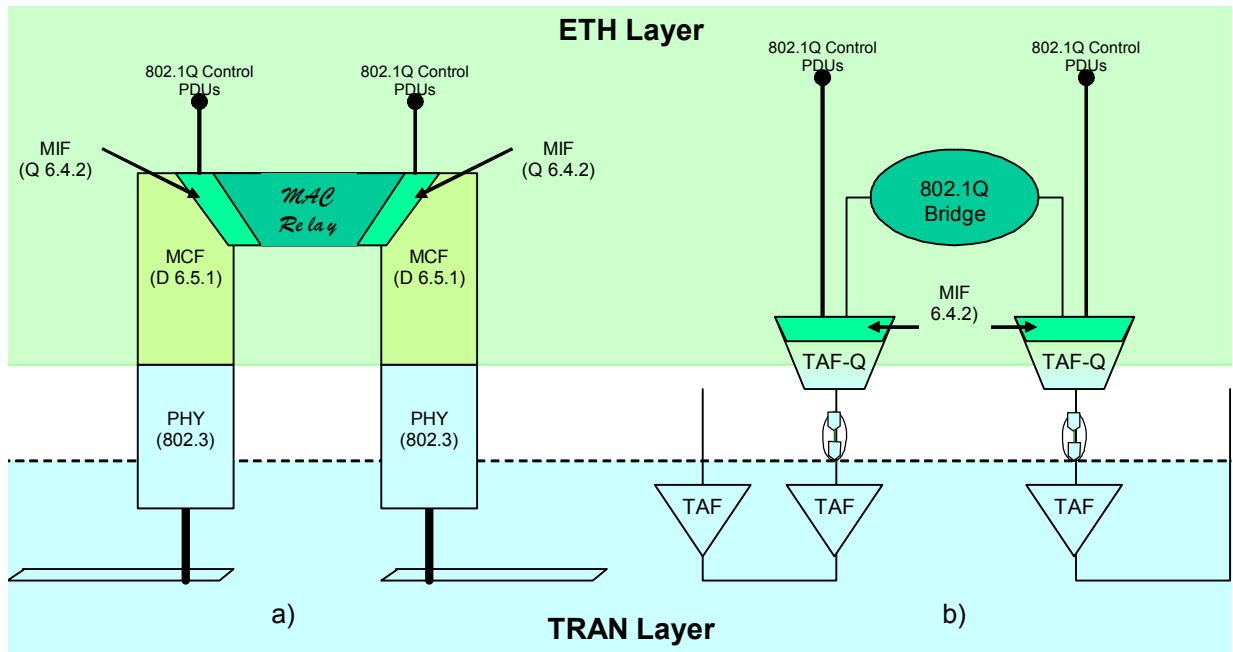
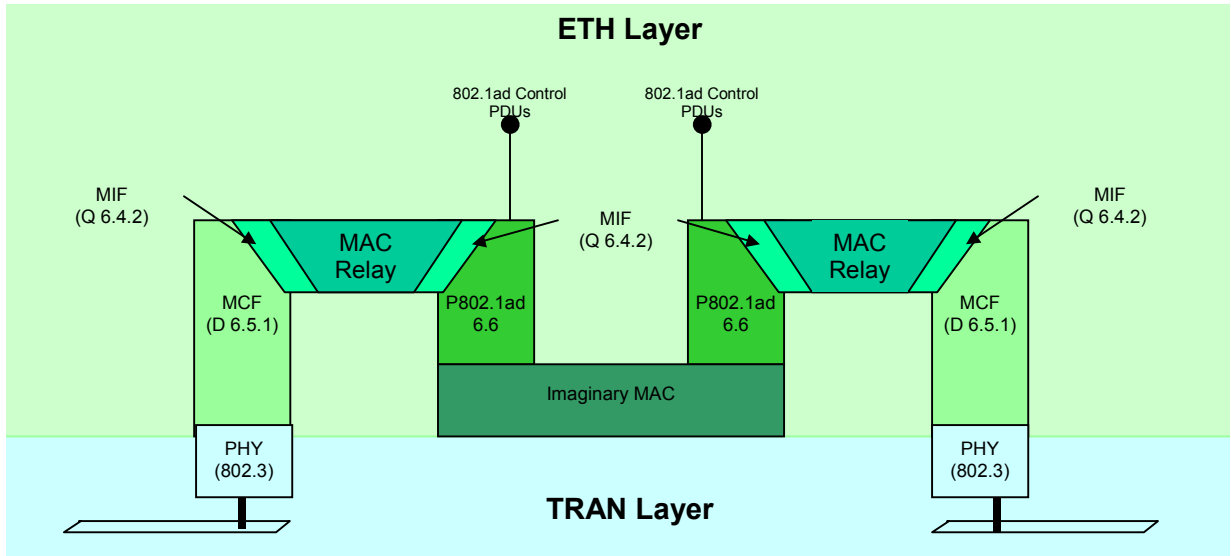

Figure 11: Basic IEEE 802.1Q Bridge Model

I.3 IEEE P802.1AD BRIDGE MODEL

Figure 12a illustrates the basic reference model for an IEEE P802.1ad Ethernet VLAN provider bridge model as per the IEEE P802.1ad specification. The model represents a simple provider bridge with no customer bridge support functionality. Figure 12b presents a mapping of the major IEEE P802.1ad VLAN provider bridge components into the MEF ETH and TRAN layers.

The IEEE 802.1ad Bridge ECF is specified as per the IEEE P802.1ad MAC Relay function. The IEEE P802.1ad TAF (TAF-AD) contains the P802.1ad MIF, the IEEE 802.1Q MIF (as per IEEE 802.1Q Section 6.4.2 [4]), the MCF (as per IEEE 802.1D Section 6.5.1 [4]) functions as well as the aspects related to the mapping of the Ethernet MAC frame into the physical medium from the various blocks of the PCS in the IEEE 802.3 PHY specifications [3].



a)

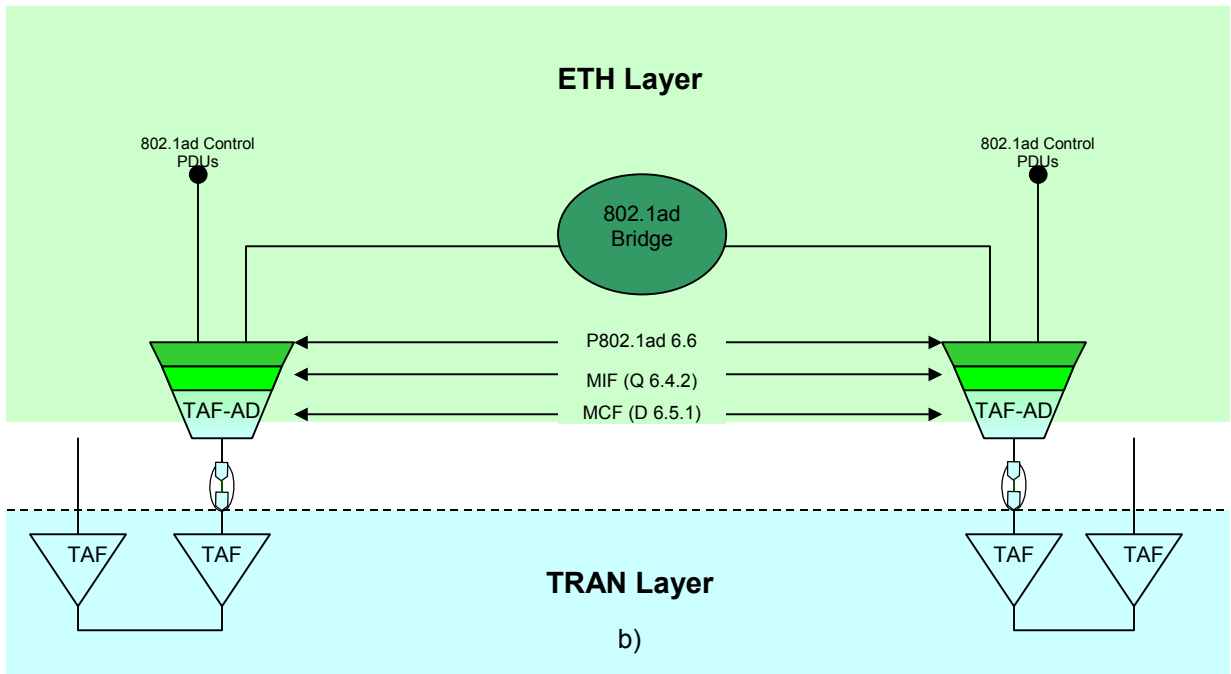

b)

Figure 12: Basic IEEE P802.1ad Bridge Model